

RACKMUX® Series

RACKMUX-D15-N-4/8/16DVIHD RACKMUX-D17-N-4/8/16DVIHD

**KVM Drawer with USB KVM Switch
and DVI Video Support
Installation and Operation Manual**



TRADEMARK

RACKMUX is a registered trademark of Network Technologies Inc in the U.S. and other countries.

COPYRIGHT

Copyright © 2008 by Network Technologies Inc. All rights reserved. No part of this publication may be reproduced, stored in a retrieval system, or transmitted, in any form or by any means, electronic, mechanical, photocopying, recording, or otherwise, without the prior written consent of Network Technologies Inc, 1275 Danner Drive, Aurora, Ohio 44202.

CHANGES

The material in this guide is for information only and is subject to change without notice. Network Technologies Inc reserves the right to make changes in the product design without reservation and without notification to its users.

TABLE OF CONTENTS

INTRODUCTION.....	1
Models Available.....	1
Types of CPUs Supported.....	1
Features.....	1
Option.....	1
MATERIALS.....	2
FEATURES AND FUNCTIONS.....	3
INSTALLATION.....	4
Rack Mounting Instructions.....	4
Optional Telco 2-Post Mounting.....	4
Connect The Cables.....	5
RS232 Connection.....	6
Power-Up Sequence.....	6
USING THE UNIMUX.....	7
Front Panel Control.....	7
Keyboard Control.....	7
Command Mode.....	7
Scan Mode.....	8
Broadcast Mode.....	8
Normal Mode.....	8
No Sun Sleep Mode.....	9
Select Country Code.....	9
RS232 CONTROL.....	10
RS232 Connections and Configuration.....	10
Remote Connection.....	10
Baud Rate.....	10
Unit Address and Loop Back.....	11
Command Protocol.....	12
NTI Switch Control Program For Windows 9X, NT, 2000, XP, And Vista.....	14
SerTest- RS232 Interface Test Program.....	14
Main Options.....	14
DISPLAY FUNCTIONS.....	16
Standard Controls.....	16
OSD Control Menu.....	17
OSD Main Menu.....	17
Brightness/Contrast Menu.....	17
Setup Menu.....	18
KEYBOARDS.....	19
Keyboard Configuration.....	20
Keyboard-To-Computer Translation.....	20
Translation Tables.....	20
TROUBLESHOOTING.....	21
RACKMUX SPECIFICATIONS.....	22
General Specs.....	22
LCD – 15”.....	22
LCD – 17”.....	22
Display Controller: DVI (-15 & -17).....	22
OSD Control Board.....	22
Keyboard.....	23
Touchpad.....	23
INDEX.....	23
WARRANTY INFORMATION.....	23

TABLE OF FIGURES

Figure 1- Mount RACKMUX to rack	4
Figure 2- Mount to Telco post with optional mounting brackets	4
Figure 3- Connect each CPU	5
Figure 4- Connect the power cord	5
Figure 5- Connect RS232 control terminal	6
Figure 6- CPU Select switches, status LEDs and Mode LEDs	7
Figure 7- Country Codes for international SUN keyboards	9
Figure 8- RS232 dip-switches	10
Figure 9- RS232 connection with Matrix-Y-1 cable	11
Figure 10- Pinout of Matrix-Y-1 cable	12
Figure 11- RS232 Communication Illustrated	12
Figure 12- OSD Controls	16
Figure 13- U.S. (English) keyboard with numeric keypad	19
Figure 14- U.K. (English) keyboard with numeric keypad	19
Figure 15- German keyboard with numeric keypad	19

INTRODUCTION

The RACKMUX-D15-N-8DVIHD is a KVM Drawer with USB KVM Switch (**RACKMUX**) that combines a rackmount 15" TFT/ LCD DVI monitor, keyboard, touch pad, and USB KVM switch (**UNIMUX**) in a space-saving 1RU industrial strength drawer. The RACKMUX is equipped with a built-in switch function, which allows control of up to sixteen DVI -enabled computers with a single keyboard, touchpad and DVI monitor. When access to a server rack is needed, the drawer can be pulled out and the display lifted up like a notebook computer, revealing the keyboard and touchpad. When the drawer is not in use, the display can be folded forward and down so the 1RU drawer can be pushed into the cabinet easily and smoothly, helping to organize and streamline busy server rooms.

The onboard USB KVM switch allows access to any DVI-enabled Windows, MAC, or SUN USB CPUs from one DVI monitor, USB keyboard and USB mouse (up to 16 CPUs). Internal microprocessor circuitry allows all USB CPUs to be booted simultaneously without keyboard error. Port selection is accomplished through switches on the keyboard tray or keyboard commands.

Models Available

- RACKMUX-D15-N-4DVIHD - KVM Drawer with 15" TFT/LCD DVI monitor and 4-port UNIMUX
- RACKMUX-D17-N-4DVIHD - KVM Drawer with 17" TFT/LCD DVI monitor and 4-port UNIMUX
- RACKMUX-D15-N-8DVIHD - KVM Drawer with 15" TFT/LCD DVI monitor and 8-port UNIMUX
- RACKMUX-D17-N-8DVIHD - KVM Drawer with 17" TFT/LCD DVI monitor and 8-port UNIMUX
- RACKMUX-D15-N-16DVIHD - KVM Drawer with 15" TFT/LCD DVI monitor and 16-port UNIMUX
- RACKMUX-D17-N-16DVIHD - KVM Drawer with 17" TFT/LCD DVI monitor and 16-port UNIMUX

Types of CPUs Supported

Any DVI-enabled USB CPU supporting USB version 1.0 or above including:

- USB WINxx
- USB MAC
- USB SUN

Features

- Entire unit is only 1RU (1.75") high
- High-quality metal construction (ideal for most industrial and commercial settings)
- 15" or 17" Rack Mount LCD Monitor features a wide viewing angle
- 1024x768 resolution for 15" monitor
- 1280x1024 resolution for 17" monitor
- A forward-folding 15" or 17" TFT LCD DVI monitor
- Includes rack mount kit suitable for SUN and most EIA 19" racks
- Fits varying rack depths from 22" to 39" deep via adjustable mounting brackets
- DVI Video Compatible
- Powered by 110 or 220VAC, 50 or 60Hz with country-specific line cord
- Auto shut-OFF switch: Turns OFF the power to the monitor when the LCD is in a folded-closed position
- Standard 3-button touchpad
- Added security with a drawer lock to prevent unwanted access
- Locking rails to prevent movement of the drawer when fully extended
- Multi-language support including: US(English), UK(English), German, French, Italian, and Spanish

Option

- Rackmounting kit for two-post Telco rack - order RL-T15-TEL

MATERIALS

Materials supplied with this kit:

- NTI RACKMUX-xx-N-yDVIHD KVM Drawer with USB KVM Switch (where xx = 15 or 17 and y= 4,8 or 16)
- Line cord, country specific
- Set of keys for keylock
- 2 Rear Mounting Brackets w/ 4 nuts
- 8pcs #10-32x3/4" screws and cage nuts for mounting to a rack
- CD with pdf of this manual
- 1- DB9 Female-to-RJ45 Female adapter
- 1- DB25 Female-to-RJ45 Female adapter
- 1- 5 foot RJ45-to-RJ45 CAT5 patch cable

Materials Not supplied but REQUIRED:

- USB-DHEXT-xx-MM cable for each CPU being connected to the switch- for DVI monitor, USB keyboard, and USB mouse support- available in 3, 6,10, and 15 foot lengths

where:

xx is the length of the cable in feet

MM indicates male-to-male connector

Cables can be purchased from Network Technologies Inc by calling (800) 742-8324 (800-RGB-TECH) in the US and Canada or (330) 562-7070 (worldwide).

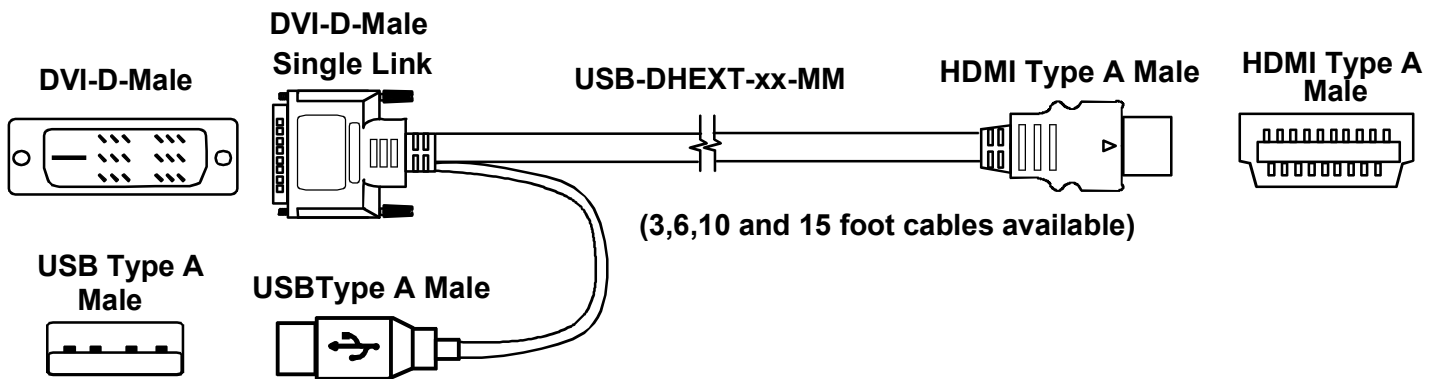

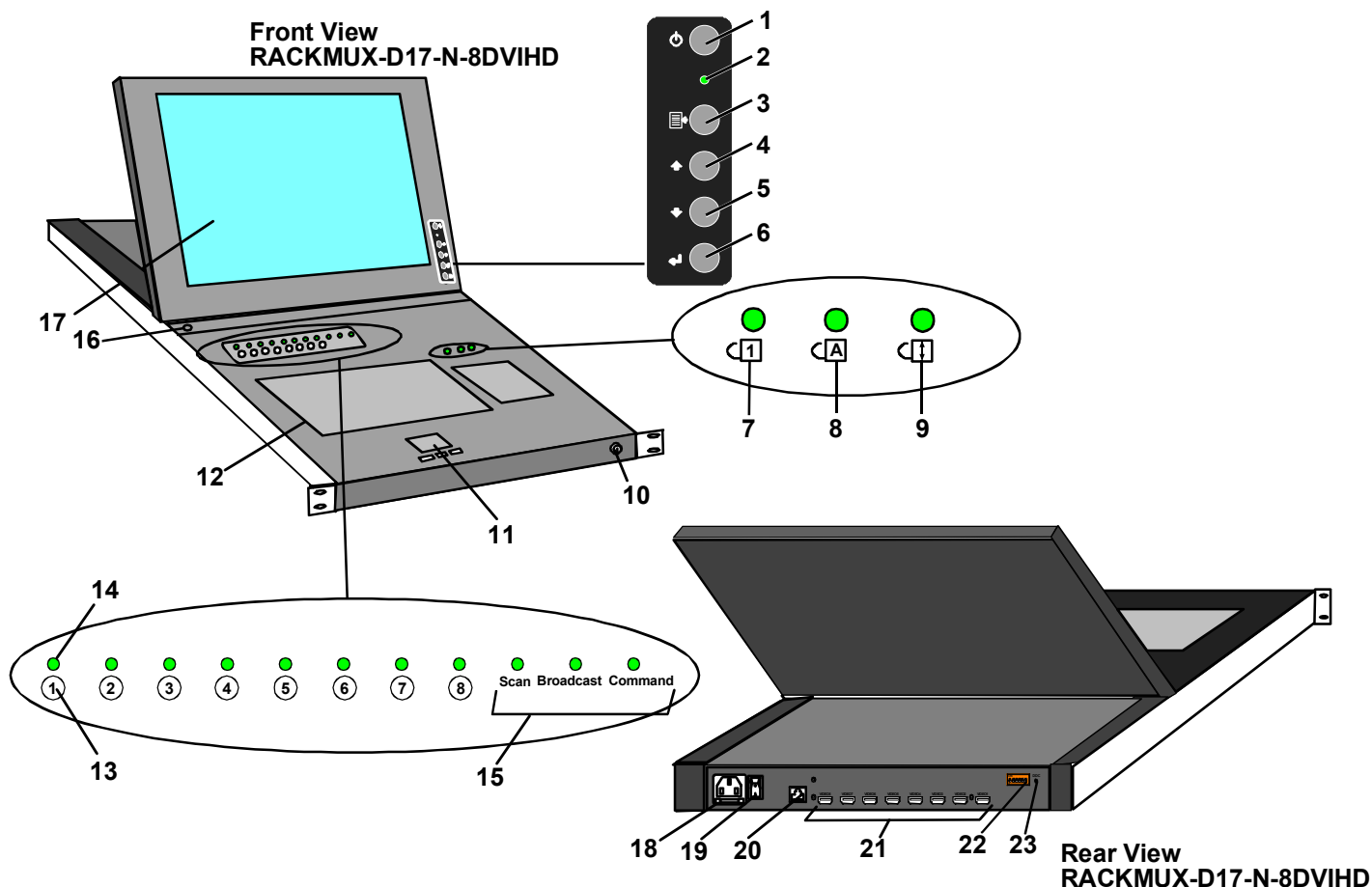

FEATURES AND FUNCTIONS

1. **Power Button-** press to turn the LCD monitor ON and OFF
2. **Power LED-** Indicates operation status
Green = Power-ON, Video Input Signal OK
Red = Suspend / Stand-by, or no Video Input Signal
3. **Menu Button-** press to turn ON the OSD menu
4. **Up Arrow Button-** press to move the cursor in the OSD menu up
5. **Down Arrow Button-** press to move the cursor in the OSD menu down
6. **Select Button-** press to select a menu item (when OSD menu is ON) or press to auto adjust the video quality (when OSD menu is OFF)
7. **NumLock LED-** illuminates when the Num Lock is ON
8. **CapsLock LED-** illuminates when Caps Lock is ON
9. **Scroll Lock LED-** illuminates when the Scroll Lock keyboard feature is ON
10. **Keylock-** to prevent unauthorized use of the RACKMUX
11. **3-button Touch Pad-** for controlling mouse movements on the monitor and controlling the computer
12. **Keyboard-** for manual data entry and computer control
13. **CPU Select Switch-** push to manually switch to a specific CPU or change the switch operating mode
14. **CPU Status LED-** for visual indication of connection between the user and a specific CPU
15. **Mode Status LEDs-** for visual indication of switch operating mode
16. **Auto Shut-OFF-** switch automatically shuts OFF the LCD display when the monitor is folded down
17. **LCD Display-** for viewing the video signal from the connected CPU
18. **IEC Connector w/Built-in 2A 240VAC Replaceable Fuse-** for attachment of the AC power cord to power the RACKMUX drawer
19. **Power Switch- to power the RACKMUX ON/OFF**
20. **RS232-** RJ45 connector- for attachment of an RS232 control cable
21. **CPU x-** HDMI Type A female connectors- for connecting USB-DHEXT-xx-MM cables from CPUs
22. **RS232 Dip Switches-** for controlling the baud rate of the RACKMUX for RS232 communication
23. **DDC-** recessed button used to reset DDC information between the RACKMUX and the connected CPU

INSTALLATION

Rack Mounting Instructions

The RACKMUX was designed to be mounted to a rack and includes mounting flanges to make attachment easy.

1. Determine the mounting height in the rack for the drawer. It should be a height comfortable to use the keyboard and see the LCD display. Mark holes in each of the 4 corner cabinet rails at points all level with each other.
2. Secure the rear brackets to the rear rack cabinet rails. Apply the top screws (supplied) for each bracket to the holes marked in step 1.
3. Lift the keyboard into position and line the studs on the left and right sides up with the slotted openings in the rear bracket. Apply the nuts (supplied) to the studs but do not tighten the nuts yet.

FYI: There are 4 mounting studs provided on each side of the RACKMUX. Depending on the depth of the rack and distance apart of the cabinet rails, the position of the rear bracket may make all 4 studs available for use. In this case, apply the 2 nuts to the studs furthest apart from each other on each side.

4. Slide the drawer in until the top holes in the front bracket flanges line up with the holes marked in step 1. Secure the front brackets on the drawer to the front cabinet rails with two screws per bracket. Be sure to tighten the screws securely. Then tighten the nuts applied in step 3.
5. Apply one more screw to each of the rear brackets to complete the installation.

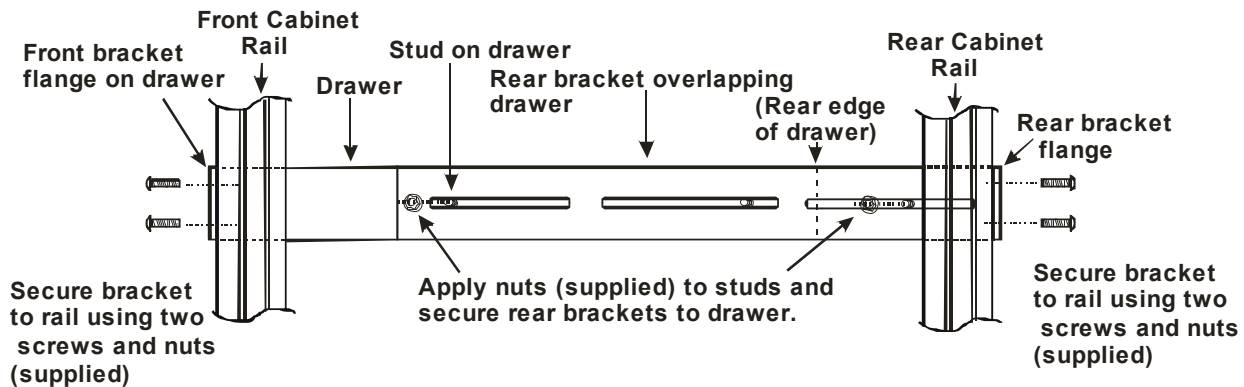
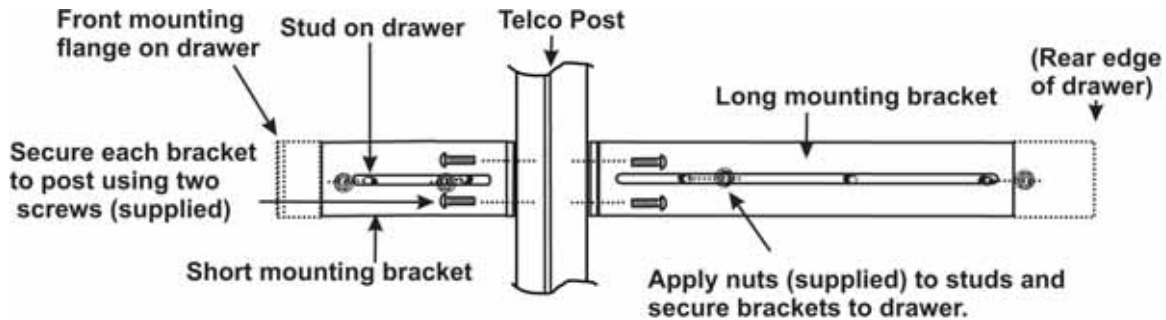

Figure 1- Mount RACKMUX to rack

Optional Telco 2-Post Mounting

If the Telco 2-post mounting bracket kit (NTI# RL-T15-TEL) is to be used, secure the short and long brackets to each side of the drawer as shown in Fig. 2. Apply 2 nuts (supplied) per bracket to secure the brackets to the drawer. Apply two #10-32x3/4" screws (supplied) per bracket to the post at the desired height. Slots are provided in the brackets to make minor depth adjustments easy. Be sure to properly tighten all nuts and screws before using the drawer.



View of right side of drawer with optional Telco mounting brackets

Figure 2- Mount to Telco post with optional mounting brackets

Connect The Cables

FYI: It is not necessary to turn the CPUs or monitors OFF during this installation.

1. Connect each CPU to the UNIMUX switch using a USB-DHEXT-xx-MM (Required-not supplied) as shown in Fig. 3.

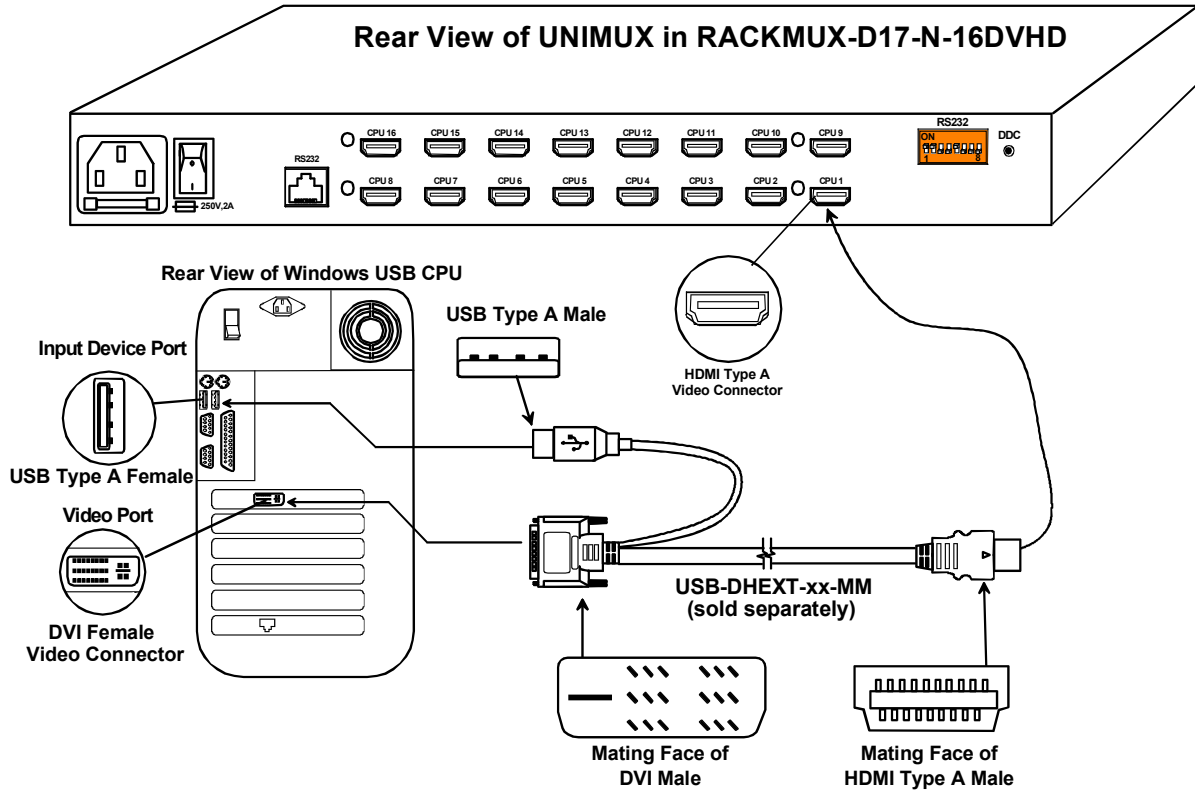

Figure 3- Connect each CPU

2. Connect the power cord to the IEC power connector.

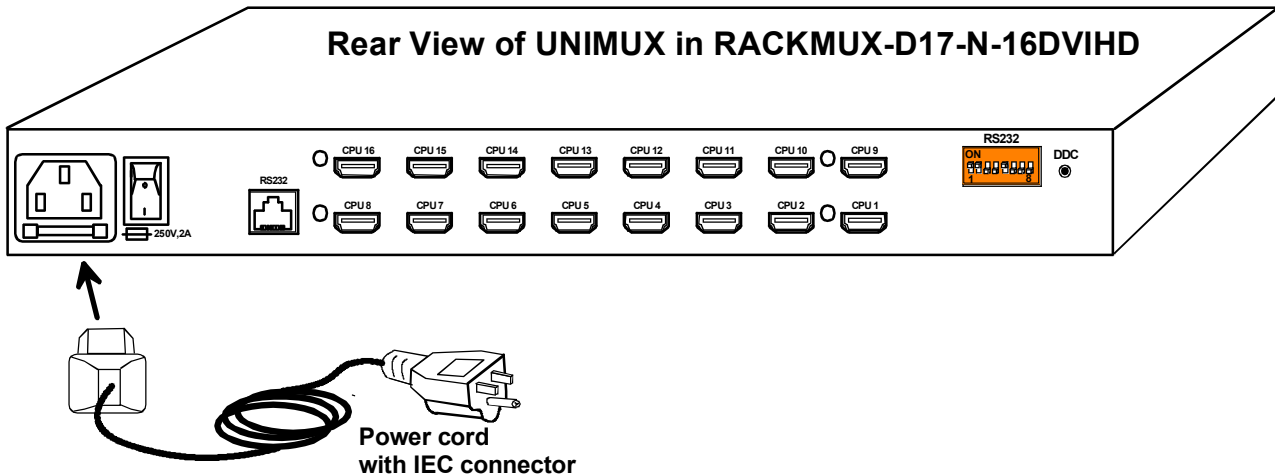

Figure 4- Connect the power cord

RS232 Connection

If RS232 control will be used, connect one end of the CAT5 patch cable (supplied) to the port labeled “RS232” on the rear of the RACKMUX. Plug the other end of the CAT5 cable into either the RJ45-to-DB9 or RJ45-to-DB25 adapter supplied, and connect the adapter to the RS232 port on the control terminal. Follow the instruction under “RS232 Control” on page 10 for configuration and use of the RS232 control feature.

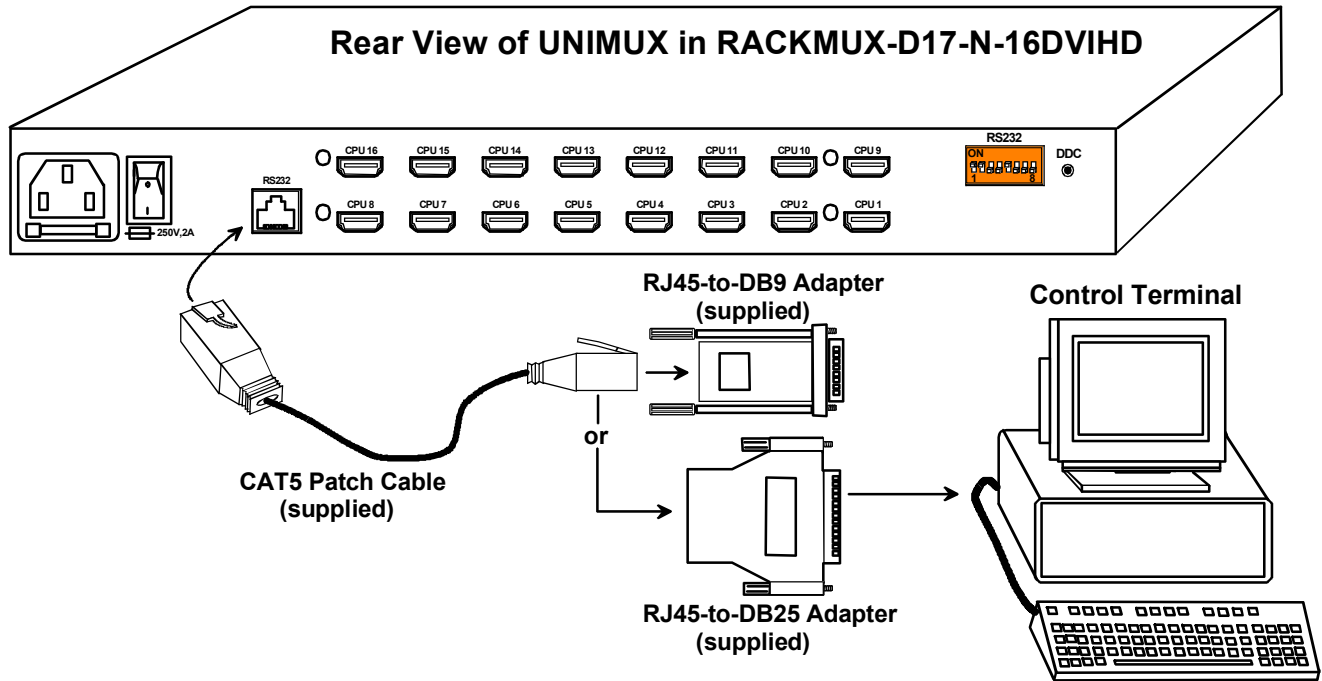

Figure 5- Connect RS232 control terminal

Power-Up Sequence

1. Using the key, unlock the drawer and slide the keyboard and LCD Display out far enough to raise the display to a comfortable viewing angle.
2. Power ON the RACKMUX with the power switch located on the rear of the drawer.
3. Power ON the monitor with the power switch located on the monitor.
4. Adjust the screen's brightness and contrast with the controls also located on the monitor— as needed.
5. Power ON any attached CPUs.

FYI: The CPUs can be powered at any time although if a CPU needs a keyboard and/or mouse at power-ON it should be powered after connecting to and powering-ON the RACKMUX.

USING THE UNIMUX

Once the RACKMUX is properly connected, the UNIMUX switch will enable a connection to be made between the attached CPUs and the monitor, keyboard, and mouse.

The UNIMUX can be controlled by three methods:

- front panel control using touch-switches and LEDs on the keyboard tray
- keyboard control through Command Mode
- RS232 control (see page 10)

Front Panel Control

There is a panel of numbered touch-switches and LEDs on the keyboard tray of the RACKMUX. There is one switch and LED for each CPU the switch will connect the monitor and input devices to. Pressing any touch-switch will connect the corresponding CPU to the monitor and input devices.

Holding down any touch-switch for more than 2 seconds will cause the UNIMUX to cycle through all modes of operation including COMMAND, BROADCAST, SCAN, and NORMAL (described in "Command Mode" below). The three MODE LEDs on the panel indicate which mode is selected. Release the touch-switch when the LEDs indicate the desired mode. When no mode LEDs are illuminated the user is in Normal Mode controlling directly the CPU to which the user is connected through the UNIMUX.

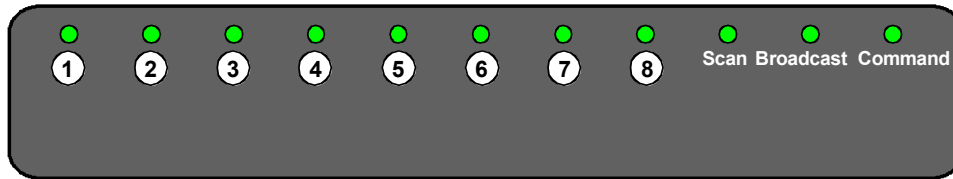

Figure 6- CPU Select switches, status LEDs and Mode LEDs

Keyboard Control

Keyboard control of the UNIMUX switch is achieved using Command Mode - operated using the keyboard. By pressing <Ctrl> + <~> (accent/tilde key), the user can enter Command Mode. Once in Command Mode, typing a series of commands will cause the UNIMUX switch to connect the user to any one CPU connected to the switch. Pressing the <Esc> key will exit Command Mode. The following instruction describes how to use the menus to operate the UNIMUX switch.

Command Mode

In order to control the UNIMUX with the keyboard connected, Command Mode must be enabled. To enter Command Mode from the keyboard:

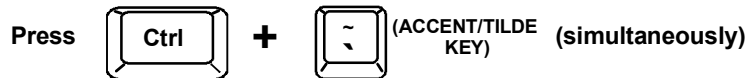

When the COMMAND LED is illuminated, all 3 LEDs on the keyboard will illuminate (caps lock, scroll lock, and num lock) to indicate that Command Mode is enabled and the following functions are available:

Basic Command Functions

Function:

Keystroke:







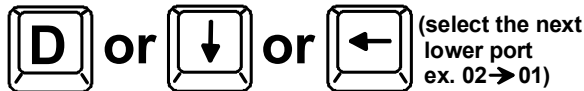









Increment Port



Decrement Port



KEY SYMBOLS LEGEND:	
OR	PRESS EITHER KEY
+	CHORDED SEQUENCE- PRESS CONSECUTIVELY AND KEEP KEYS PRESSED UNTIL ALL ARE PRESSED.
-	PRESS CONSECUTIVELY

Toggle Scan Mode ON and OFF		(The SCAN Mode LED will also toggle ON and OFF)
Toggle Broadcast Mode ON and OFF		(The Broadcast Mode LED will toggle ON and OFF.)
Sets scan time-out period for each port.	 -  -  - 	(xxx from 002 to 255. ie. T002 would set the time-out period for 2 seconds)
Selects a specific port	 -  - 	(Pxx would be P01, P02, etc.)
Configure port to connect To a MAC CPU	 +  + 	(xx= 01-8 <M> + <0> + <1> will enable function on Port 1 <M> + <0> + <4> will enable function on Port 4. Keyboard LED's will flash once to confirm command.)
Configure port to connect To a WINDOWS or SUN CPU	 +  + 	(xx= 01-8 <W> + <0> + <1> will disable function on Port 1 <W> + <0> + <4> will disable function on Port 4. Keyboard LED's will flash once to confirm command.)
Exit Command Mode		<div style="border: 1px solid black; padding: 5px;"> <p>FYI: The user must exit Command Mode to type to a CPU.</p> <p>To exit Command Mode, either hold down any touch-switch on the front panel for more than 2 seconds, OR press <ESC> on the keyboard.</p> </div>

Scan Mode

To activate or deactivate Scan Mode press <S> from the Command Mode menu. When in Scan Mode the switch scans to each port with a CPU powered-ON. (The SCAN LED on the front panel will illuminate and remain ON while in Scan Mode.) The port with the CPU powered-ON remains active while in use until it becomes idle for the configured dwell time (default time-out period is 5 seconds) before switching to the next powered-ON CPU port. See Command Mode section above for configuring the scan dwell time.

Note: The keyboard and mouse must remain idle for the full scan dwell time before the switch selects the next active port.

To begin scanning, press <Esc> to exit Command Mode.

Broadcast Mode

To activate or deactivate Broadcast Mode, press from the Command Mode menu. Broadcast Mode enables the user to type characters to all powered-ON CPUs simultaneously.

Note: The user must type somewhat slowly (less than 20 wpm) when in Broadcast Mode and cannot use the <Backspace> key.

To begin broadcasting, press <Esc> to exit Command Mode.

Normal Mode

When the Broadcast, Scan, and Command LEDs are all OFF the user is in Normal Mode, controlling the CPU to which the user is connected through the UNIMUX.

No Sun Sleep Mode

Note: It is necessary to configure a Sun CPU (most versions) such that the Sleep Mode is not enabled. If the Sun CPU goes into Sleep Mode either automatically or manually, the user must reboot the Sun CPU in order to resume use of the Sun CPU.

To disable the Sleep Mode, perform the following steps:

1. Select "Power Manager"
2. Look for "Device Idle Time Before Power Saving Starts"
3. Select "Always ON"
4. Look for "Override Device Idle Time For:"
5. Make sure neither "Monitors" nor "Disks" are selected.

Select Country Code

It is possible to configure the UNIMUX to emulate a specific international Sun keyboard regardless of what actual keyboard is connected. This is recommended when the CPU needs the layout code (i.e. a SUN CPU) and the keyboard doesn't have an explicit layout code (i.e. some Windows keyboards). To do this, manually set the UNIMUX to indicate the international keyboard identification number to the CPU using the following procedure;

1. Enter Command Mode
2. Type Lxx, where xx is the number from the list below that corresponds to the desired country code
3. Exit Command Mode

Note: If any SUN CPUs are connected to the UNIMUX, they must be rebooted. Keyboard configuration is only read by SUN CPUs on startup.

Country Codes

00	Auto Detect	13	International (ISO)	26	Swedish
01	Arabic	14	Italian	27	Swiss/French
02	Belgian	15	Japan (Katakana)	28	Swiss/German
03	Canadian-Bilingual	16	Korean	29	Switzerland
04	Canadian-French	17	Latin American	30	Taiwan
05	Czech Republic	18	Netherlands/Dutch	31	Turkish
06	Danish	19	Norwegian	32	UK
07	Finnish	20	Persian (Farsi)	33	US
08	French	21	Poland	34	Yugoslavia
09	German	22	Portuguese		
10	Greek	23	Russia		
11	Hebrew	24	Slovakia		
12	Hungary	25	Spanish		

Figure 7- Country Codes for international SUN keyboards

RS232 CONTROL

RS232 enables the UNIMUX to be remotely controlled via RS232. To control the UNIMUX via RS232 the user has three options:

- write a program that runs on a PC using the Command Protocol (page 12)
- use the NTI Switch Control Program (page 14) provided on the CD
- use the SerTest program (page 14) provided on the CD

RS232 Connections and Configuration

Remote Connection

The RS232 Interface is designed to meet the RS232C standard and can be controlled from any CPU or other controller with an RS232 communications port. The pin-out for the RJ45 connector on the unit is as follows:

RS232 (RJ45) CONNECTOR

PIN	SIGNAL	FUNCTION
1	-	No connection
2	-	No connection
3	RX+	Receive data (TXD at host)
4	GND	Ground
5	-	No connection
6	TX+	Transmit data (RXD at host)
7	-	No connection
8	-	No connection

A 5 foot patch cable and two adapters, RJ45-to-DB9 and RJ45-to-DB25, have been provided for connection to most CPUs (see page 6).

Baud Rate

The baud rate can be changed by powering down the unit, changing the 8 position RS232 DIP switch on the rear of the UNIMUX, and then powering back up. This table shows how to set the baud rate. (Fig. 8 shows switches in their factory-default position.)

DIP SWITCH		BAUD RATE
3	2	
OFF	OFF	2400
OFF	ON	9600 (default)
ON	OFF	19200
ON	ON	38400

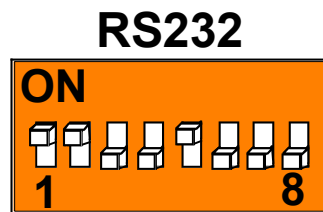

Figure 8- RS232 DIP switches

Unit Address and Loop Back

To allow multiple units to be controlled from a single CPU serial port, the RS232 control interface is designed to allow "daisy chaining" up to 7 units. By setting the appropriate RS232 DIP switches, each unit can be given a unique address (1-7). Then the unit will only respond to commands on the bus if its address is embedded in the command. Use the following table to set the unit address.

DIP SWITCH				UNIT ADDRESS
8	7	6	5	
OFF	OFF	OFF	OFF	0 (not valid)
OFF	OFF	OFF	ON	1 (default)
OFF	OFF	ON	OFF	2
OFF	OFF	ON	ON	3
OFF	ON	OFF	OFF	4
OFF	ON	OFF	ON	5
OFF	ON	ON	OFF	6
OFF	ON	ON	ON	7

Note: The "loop back" RS232 DIP switch (RS232 DIP switch 1) should be ON for each unit in the chain.

Note: Pin 4 on the RS232 dip switch is not used.

In order to connect multiple switches (up to 7) with RS232 connections to the same CPU, an NTI Matrix-Y-1 cable must be used. Connect the Matrix-Y-1 cable (sold separately) between the RJ45-to-DB9 serial adapter (supplied) and the CPU as shown in Fig. 9.

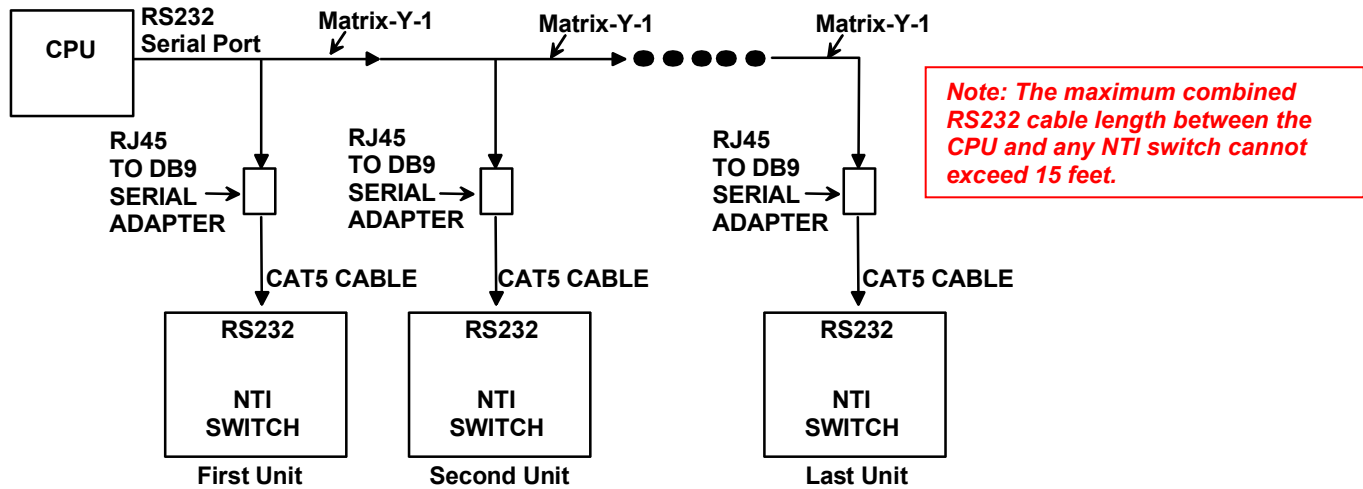

Figure 9- RS232 connection with Matrix-Y-1 cable

Legend: (All numbers must be two digits)

- SW : Switch (01-7) (Unit Address)
- OP : Output (User) Port (01)
- BR : Baud Rate (12 =1200, 24=2400, 48=4800, 96=9600 baud)
- IP : Input (CPU) Port (01-MAXINPUTS)
- <CR> : Carriage Return (Hex 0xD)

Note: For units with one output (user) port, use 01 for the output selection.

Command Definitions

Command String	Good Response	Description
CS SW,IP,OP	*<CR>	Connect Output (User) Port To specific Input (CPU) Port
RO SW,OP	*<CR>IP<CR>	Read Connection For Output (User) Port to Input (CPU) Port
CB 00,BR	None	Change Baud Rate For All Switches (BR=12 (1200), 24 (2400), 48 (4800), 96 (9600) baud)- see “Note” below
RS SW	*<CR>	Internal Reset
RU SW	*<CR>IP,OP<CR>	Read Unit Size
SS SW,00	*<CR>	Disable Autostatus feature (see below)
SS SW,01	*<CR>	Enable Autostatus feature (see below)
GO SW,OP	*<CR>go SW,OP:IP<CR>	Read connection of a Output (User) Port to Input (CPU) Port (different response format than RO command)
GM SW,00	*<CR>go OP,IP (all ports)<CR>	Read connection matrix of all Output (User) ports

If the first field is not a known command (as listed above) or SW field is different from the unit address programmed at the dip switch (page 11), the command will be ignored. If the SW field corresponds to the unit address, but if the syntax is wrong after this field, the switch will answer with a bad response ?<CR>.

Syntax example:

CS 01,05,01<CR> (insert the space and commas as shown)
 which means "At the switch with unit address 01, connect CPU port 05 to user port 01"

The switch will answer with:

***<CR>**

The HEX code representation of example above is:

Byte 1	Byte 2	Byte 3	Byte 4	Byte 5	Byte 6	Byte 7	Byte 8	Byte 9
'C' (0x43)	'S' (0x53)	Space (0x20)	Switch – 1st digit (0x30)	Switch – 2nd digit (0x31)	',' (0x2C)	Output – 1st digit (0x30)	Output – 2nd digit (0x35)	',' (0x2C)

Byte 10	Byte 11	Byte 12
Input –1st digit (0x30)	Input –2nd digit (0x31)	<CR> (0x0D)

Note: a change in the baud rate using RS232 will only be effective until the UNIMUX is power- cycled. The DIP switch positions (page 10) will determine the set baud rate each time the UNIMUX is powered ON.

Response:

Byte 1	Byte 2
'*' (0x2A)	<CR> (0x0D)

Autostatus

When Autostatus is enabled, any output (user) -to-input (CPU) connection change in the UNIMUX will cause an Autostatus message to be sent via RS232 to the administrator. The format of the message would be "pc SW,OP:IP<CR>"

Example of an Autostatus message:

pc 01,01:04<CR>

which means "At the switch with unit address 01, the output (User) (01) has changed connection to input (CPU) port 04."

Note: An Autostatus message to the administrator will be delayed by any RS232 traffic being received by the switch from the administrator.

By default, Autostatus is disabled and must be manually enabled.

NTI Switch Control Program For Windows 9X, NT, 2000, XP And Vista

The NTI Switch Control Program is an easy and powerful graphical program that controls NTI switches through an RS232 interface. The NTI Switch Control Program is included on the CD packaged with the UNIMUX. The NTI Switch Control Program is downloaded by clicking on the link "Download NTI Switch Control Program".

To install the NTI Switch Control Program after downloading

1. Locate the **Setup.exe** in the directory the program was downloaded to and double-click on it
2. Follow the instructions on the screen

Note: In order to use the NTI Switch Control Program to control the UNIMUX, the UNIMUX RS232 port must be set at a baud rate of 9600 bps (see page 10).

The NTI Switch Control Program performs best on monitors set to a screen resolution of at least 800 X 600. Instruction for using the NTI Switch Control Program is available by opening "MSCP Help" in the "NTI" program group once the program has been installed and is open on the screen.

To open "MSCP Help" from the Windows desktop

1. Click on **START**
2. Click on **PROGRAMS**
3. Click on **NTI**
4. Click on **MSCP Help**

SerTest- RS232 Interface Test Program

This software allows a user to test the functions of an NTI server switch, matrix switch or Multi-user/Multi-platform/Single-user switch RS232 interface. The SerTest program is automatically loaded when installing the NTI Switch Control Program as described above. The SerTest program, located in the NTI program group, generates a main menu with the 4 selections described below:

Main Options

- Switch Operations - send commands to the unit.
- Ethernet Operations - set Ethernet connection variables (not applicable to this model)
- Setup Options - set COM port, baud rate, and unit address
- About SerTest - display the program version

If Matrix Operations is selected, the following menu is displayed:

SWITCH OPERATIONS

- 1) Reset Unit
 - send a reset command to the switch
 - the current unit address is displayed in parentheses
- 2) Reset All Units
 - send an internal reset command to all switches
- 3) Connect Output/User to an Input/CPU
 - connect an output to an input
- 4) Connect All Outputs/Users to an Input/CPU (not applicable to this model)
 - connect all outputs to an input
- 5) Connect Audio Output/User to an Input/CPU (not applicable to this model)
 - connect an output to an input
- 6) Connect All Audio Outputs/Users to an Input/CPU (not applicable to this model)
 - connect all outputs to an input
- 7) Change Mute Status for Audio Output/User (not applicable to this model)
 - mute or un-mute the Audio port output

- 8) Change Volume for Audio Output/User (not applicable to this model)
 - change Audio port output volume
- 9) Read Connection for Output/User
 - read what input is connected to the specified output
- a) Read Connection for Audio Output/User (not applicable to this model)
 - read what input is connected to the specified output
- b) Read Mute Status and Volume for Audio Output/User (not applicable to this model)
 - read the volume and the mute status of the specified output
- c) Read Unit Size
 - read the switch size (number of inputs and outputs)
- d) Read Unit Version/Revision String (not supported by this model)
 - read a string containing the switch version, type, and size
- e) Save I/O Connections into Unit Memory (not applicable to this model)
 - save the connections into switch memory bank
- f) Restore I/O Connections from Unit Memory (not applicable to this model)
 - restore the connections from switch memory bank
- g) Save All Units I/O Connections into Units Memory (not applicable to this model)
 - save the connections into switch memory bank, command for all switches
- h) Restore All Units I/O Connections from Units Memory (not applicable to this model)
 - restore the connections from switch memory bank, command for all switches
- i) Change All Units Baud Rate (9600/COM1)
 - change RS-232 Baud rate of all switches
 - the current baud rate and serial port are displayed in parentheses

Note: a change in the baud rate using SERTEST will only be effective until the UNIMUX is power-cycled. The DIP switch positions (page 10) will determine the set baud rate each time the UNIMUX is powered ON.

ETHERNET OPERATIONS (not applicable to this model)

SETUP OPTIONS

- 1) select Com port current: (COM1:)
 - select PC serial port
 - the current PC serial port is displayed in parentheses
- 2) select Baud rate current: (9600)
 - select PC serial port baud rate
 - the current baud rate is displayed in parentheses
- 3) set unit Address current: (1)
 - select the unit address of the switch to be connected to by this program
 - the current address is displayed in parentheses

For any selection that requires user input, the user is prompted. When commands are sent to the UNIMUX, the command string and UNIMUX responses are echoed to the screen. All commands generated by the program are formatted according to the information provided in sections above. If any transmission problems are detected, an error message is displayed.

Press <Esc> or <Enter> to back out to the main menu and press again to exit.

DISPLAY FUNCTIONS

An NTI RACKMUX with a 17" monitor supports resolutions up to SXGA (1280x1024) with a refresh rate at between 55 and 76Hz. A 15" monitor supports resolutions up to XGA (1024x768). The quality of the image on the LCD monitor is adjustable using an On Screen Display (OSD) menu using the control buttons on the RACKMUX.

Standard Controls

The RACKMUX has 5 standard control buttons and a power LED. The 5 standard control buttons operate as follows:

- The **Power** button turns the RACKMUX LCD and backlight ON and OFF as desired.
- The **Power LED** located immediately below the Power button is a dual color LED. It will illuminate with a green color when the RACKMUX is powered ON and working properly. It will illuminate with a red color if the RACKMUX is powered ON but there is no input signal detected.
- The **Menu** button is used to bring up the OSD menu where the various settings of the LCD display can be adjusted. Once the OSD screen is displayed, the Menu button is used to make selections within the menus. See "OSD Control Menu" (below) for more on LCD display settings.
- The **Up and Down Arrow** buttons are used to navigate through the menus. Move the cursor up or down as desired to highlight an item for selection. Once an item is highlighted, pressing the Menu button will select it.

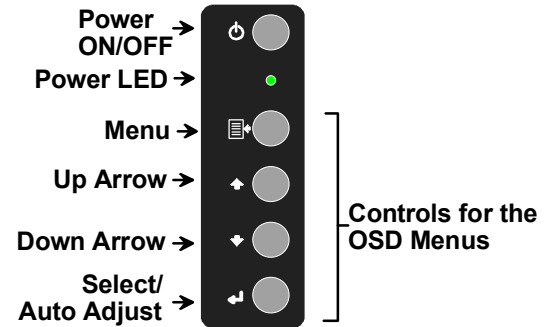

Figure 12- OSD Controls

Note: When the OSD Menu is OFF, the Up Arrow is used to toggle between a "PC" (VGA) and "Digital" (DVI) input source.

- The **Select** button is used to make selections within the OSD menus when the OSD menu is ON. When the OSD menu is OFF, the Select button will act as an **Auto Adjust** button to keep the user from having to use the menus to adjust the quality of the image on the monitor.

Note: In order to display the OSD Menu, the RACKMUX must first be connected to a video source (see "Connect the Cables" – page 5).

Note: If the message "NO SIGNAL" appears when the monitor is powered-ON, the monitor may be set for a "PC" (VGA) input source. Press the Up Arrow button on the monitor to toggle the monitor input source setting to "Digital" (DVI).

OSD Control Menu

The OSD (On Screen Display) Menu enables the user to select the desired characteristics of the LCD display. To activate the OSD Menu, press the Menu button (above). To turn the Menu back OFF, either select "EXIT" from the main menu or just wait 10-60 seconds and it will automatically be cleared from the screen. Any changes made before exiting the menu will be saved.

OSD Main Menu



Note: In order to display the OSD Menu, the RACKMUX must first be connected to a video source (see "Connect to a CPU" – page 5).

Note: If menu does not appear when the Menu button is pressed, the monitor may be set for a "PC" (VGA) input source. Press the Up Arrow button on the monitor to switch it to a "Digital" (DVI) input source.

Selection	Purpose	Range
Brightness/Contrast	Increase/decrease panel brightness/contrast level	1-100
Setup	<ul style="list-style-type: none"> Control OSD Image position on screen Set time OSD will stay on screen before auto shutoff Select the language of the OSD menu Select Input Source to display 	<ul style="list-style-type: none"> 0-4 10 to 60 seconds English, Spanish, German, Italian, or French Digital or PC (must be set to Digital)
Exit	Exit from the OSD control menu	

Brightness/Contrast Menu

Selecting the Brightness/Contrast menu will bring up a screen in which the user can adjust the brightness and contrast levels of the LCD display. Using the Up or Down arrows to navigate the menu, highlight either the BRIGHTNESS or CONTRAST sections and press the Select button to choose the option to adjust. Then use the Up or Down Arrow to adjust the setting. Select EXIT when finished to return to the Main Menu.

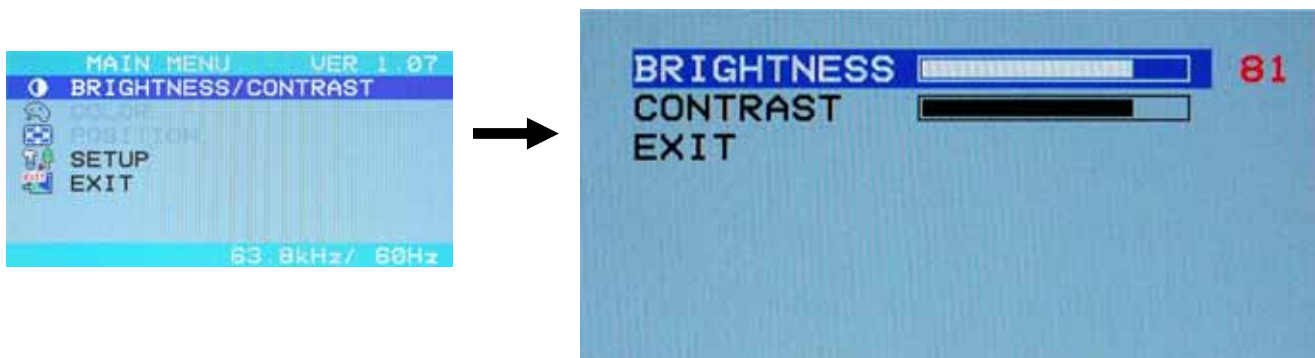

Setup Menu

Selecting the Setup menu will bring up a screen in which the user can adjust

- OSD POSITION-the position of the OSD menus on the LCD display (positions 0-4)
- OSD TIME-the length of time the user can be idle before the OSD menu automatically exits (adjustable from 10 to 60 seconds)
- LANGUAGE-the language that the OSD menu will be presented in
- INPUT SOURCE- the type of signal that is coming from the CPU, either Digital (DVI) or PC (VGA)

NOTE: As used on this RACKMUX, the INPUT SOURCE must be set to “Digital”.

With the item highlighted, (use the Up or Down arrow to move between them), press the Select button to choose the option to adjust. Then use the Up or Down Arrow to adjust the setting as needed. Select EXIT when finished to return to the Main Menu.

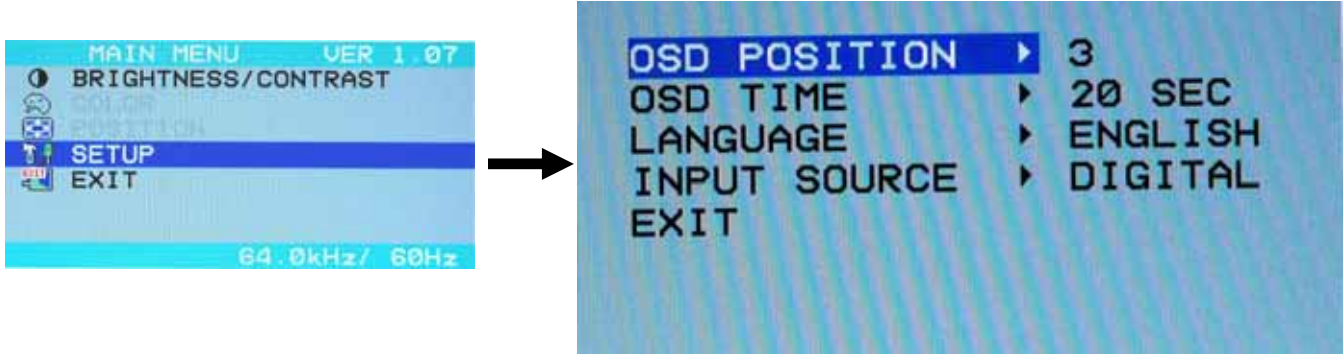

OSD Image can be moved to different points on the display

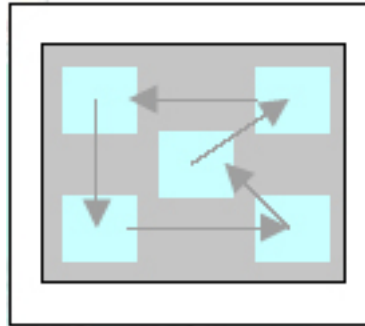

KEYBOARDS

The keyboard on the RACKMUX is a standard Windows keyboard with 17-key numeric keypad.

Note: The “Fn” key is not an active key on this keyboard.

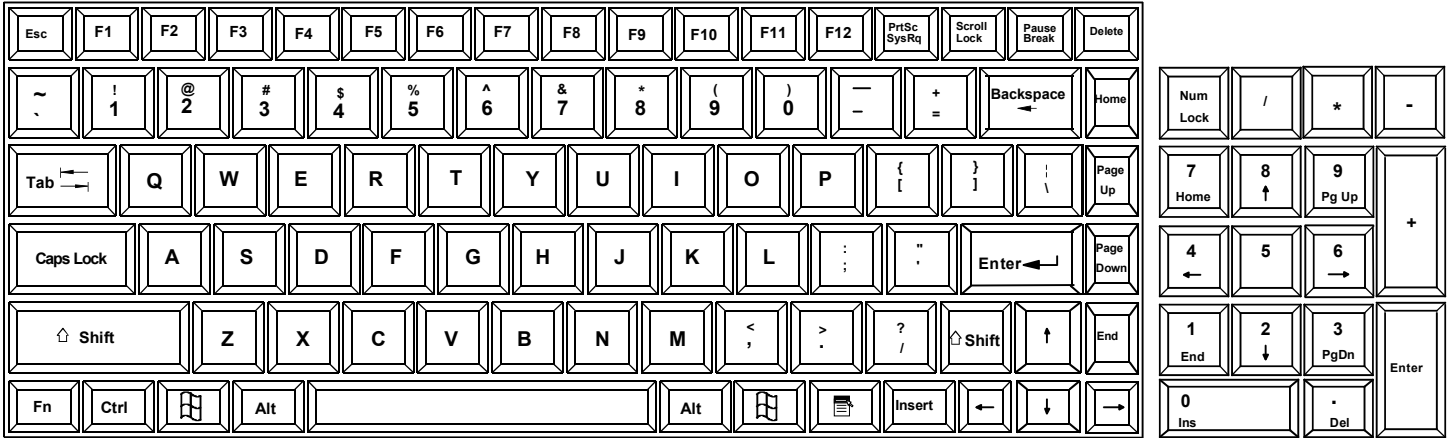

Figure 13- U.S. (English) keyboard with numeric keypad

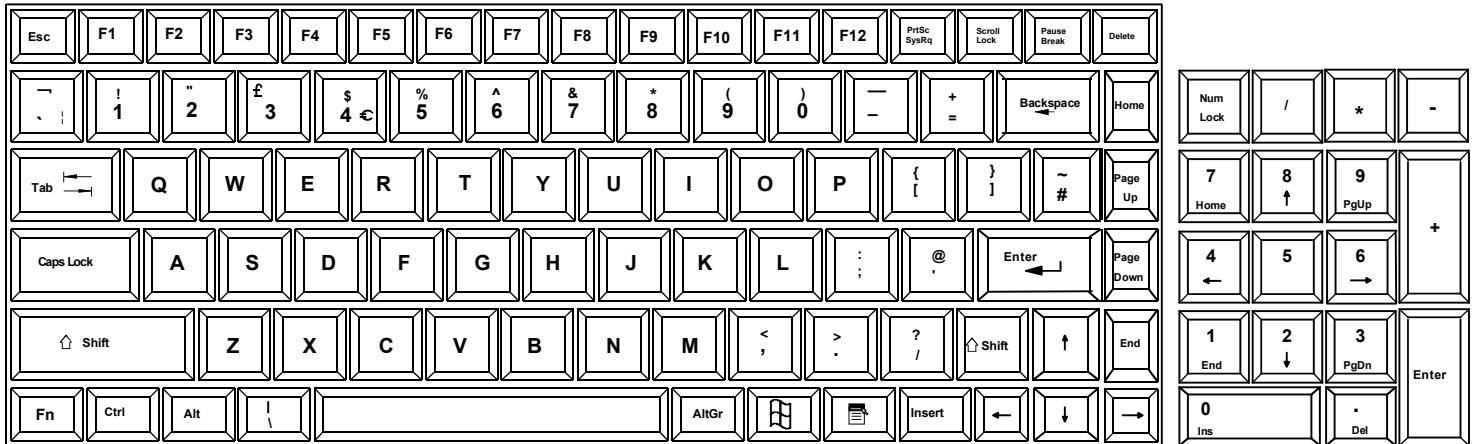

Figure 14- U.K. (English) keyboard with numeric keypad

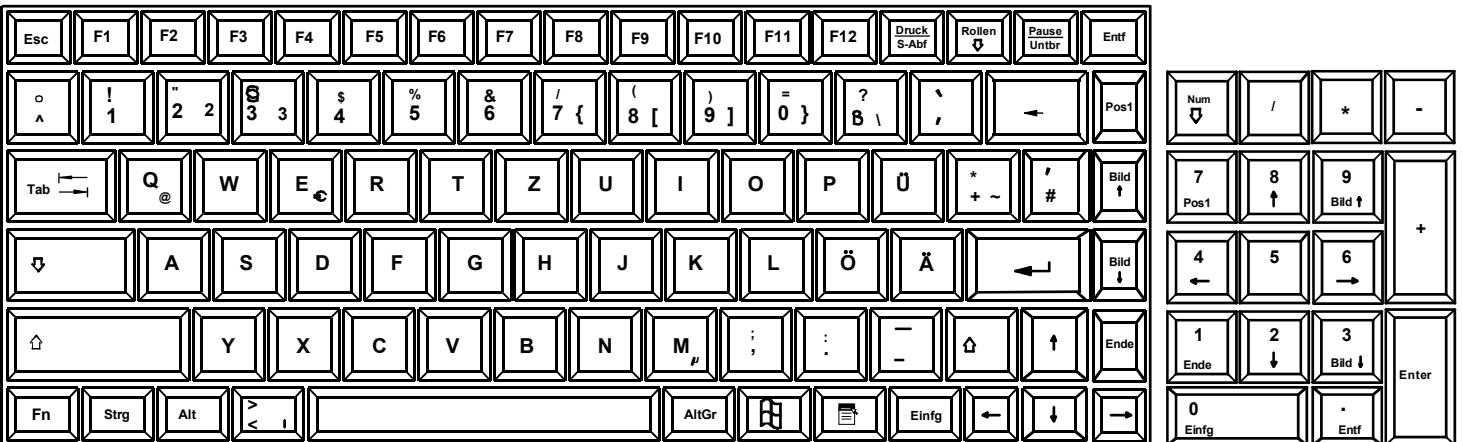

Figure 15- German keyboard with numeric keypad

Keyboard Configuration

The keyboard configuration of each CPU is saved in the UNIMUX switch. For example, if the CPU attached to Port 2 had CAPS LOCK and NUM LOCK selected the last time that CPU was accessed, then they will automatically be set when that CPU is accessed again.

Keyboard-To-Computer Translation

The UNIMUX switch enables a mixture of otherwise incompatible peripheral computer components to be connected together. This is accomplished by performing keyboard-to-computer translations automatically (i.e. translate the RACKMUX Windows-style keyboard and mouse to a SUN type CPU). The chart below shows key combinations for performing non-Windows functions in SUN and MAC CPUs.

Translation Tables

Use the charts below to type SUN's additional keys with the RACKMUX keyboard:

SUN Extra Keys

RACKMUX Keyboard	Sun Extra Keys
Space Bar + F1	Stop
Space Bar + F2	Again
Space Bar + F3	Props
Space Bar + F4	Undo
Space Bar + F5	Front
Space Bar + F6	Copy
Space Bar + F7	Open
Space Bar + F8	Paste
Space Bar + F9	Find
Space Bar + F10	Cut
Space Bar + F11	Help
Space Bar + F12	Compose
Space Bar + Up Arrow	Volume +
Space Bar + Down Arrow	Volume -
Space Bar + Left Arrow	Mute

Power Key Emulation

RACKMUX keyboard	Mac CPU	Sun CPU
SB+RT Arrow	Power	Power

TROUBLESHOOTING

PROBLEM: Keyboard Errors

SOLUTION: Check cable connections on each CPU and the switch.

PROBLEM: No Video

SOLUTION: Check cable connections on each CPU and the switch. Verify that keyboard and video connect from each CPU to matching ports. After reconnecting, CPU may need to be re-booted in order to sense the monitor connection.

PROBLEM: Keyboard/ Mouse does not work

SOLUTION: UNIMUX may be in Command mode (NumLock, ScrollLock, and CapsLock LEDs are illuminated). Only Command mode commands will be recognized while in Command mode. Press <Esc> to exit Command mode.

PROBLEM: Scan or Broadcast does not work

SOLUTION: After enabling the Scan or Broadcast mode, the user must exit Command mode for Scanning or Broadcasting to begin.

PROBLEM: In Broadcast mode, the response is quite slow or some data gets lost

SOLUTION: In Broadcast mode the data can only be entered at a rate of less than 20wpm. Try slowing down the typing rate.

PROBLEM: No Video on RACKMUX LCD monitor

SOLUTION: Make sure LCD monitor is in Digital mode, not PC mode. Adjust accordingly the OSD setting on LCD monitor (See Setup Menu- page 18)

RACKMUX SPECIFICATIONS

General Specs

Case Material.....	Electro-galvanized steel black powdercoated
Dimensions WxDxH (in.).....	19x21.9x1.75
Supported Rack Depths.....	Adjustable 22" -39"
Input Power.....	AC 110 or 220V, 50 or 60 Hz
Operating Temperature.....	0-40°C
Storage Temperature.....	-20-60°C
Relative Humidity.....	20-90%, non-condensing
Approvals.....	All parts comply with RoHS

LCD – 15”

Display area.....	304.1mm (W)x228.1 (H) (15 inch diagonal)
Panel Type.....	TFT Active
Number of Pixels	1024 (H)x768 (V)
Number of Colors.....	16.2 Million
Pixel Pitch	0.297(H)x0.297(V)
Color Pixel Arrangement.....	RGB Vertical Stripe
Brightness.....	250cd/m ² (Nits)
Response Time.....	16ms
Viewing Angle	Horizontal: 140°; Vertical: 125° (Typ.)
Optimum Viewing Direction.....	6 o'clock
Backlight Unit.....	2x CCFLs (Top & Bottom, edge-light)
Operating Lamp Life	30,000-40,000 hrs
Contrast Ratio.....	500:1

LCD – 17”

Display area.....	337.92mm (W)x270.336 (H) (17 inch diagonal)
Panel Type.....	TFT Active
Number of Pixels	1280 (H)x1024 (V)
Number of Colors.....	16.2 Million (6 bits + FRC)
Pixel Pitch	0.264(H)x0.264(V)
Color Pixel Arrangement.....	RGB Vertical Stripe
Brightness.....	300cd/m ² (Nits)
Response Time.....	5.5ms
Viewing Angle	Horizontal: 140°; Vertical: 130° (Typ.)
Optimum Viewing Direction.....	6 o'clock
Backlight Unit.....	CCFL, 4 Tables, Edge-Light (2 Top/2 Bottom)
Operating Lamp Life	40,000-50,000 hrs
Contrast Ratio.....	500:1

Display Controller: DVI (-15 & -17)

Connector.....	DVI-D, female
Video Format	VGA, SVGA, XGA, SXGA
Signal Input (from Video Source).....	Digital TMDS
Sync Range	H: 31 ~ 80KHz, V: 55 ~ 76Hz
OSD Control.....	Menu, Up, Down, Select, Power (5 keys)
Plug and Play.....	VESA DDC 2B Ver1.3

OSD Control Board

OSD Control	5 Keys
Power Key	Power ON/OFF
Menu Key.....	Activates Menu
Up, Down Keys	Navigation Control
Select Key.....	Select (when in Menu); Auto Adjust (not in menu)
LED.....	Indicates Operation Status
.....	Green = Power-ON, Video Input OK
.....	Red = Suspend / Stand-by, or Input Out of Range

Keyboard

No. Of Keys	83 Keys (US), 84 keys (German, French, Italian, Spanish)
Key Switch Type	Membrane switch
Keytop Style	Rectangular Cylindrical
Operating Force	50gf +/- 25gf
Stroke	3.0mm +/-0.5mm
Tactile	20 gf typ.
Height	8.5 mm
Operating Life	10M operations, minimum
Interface	Row and column matrix
Key Switch Bounce	10 ms, maximum
Supported Platforms	USB
CPU Connectors	USB Type B

Touchpad

Motion Detection Method	capacitance sensing
X/Y Position Sensing Resolution	40 counts/mm
X/Y Position Reporting	Relative (Similar to mouse)
Tracking Speed	Up to 1016 mm/sec
Touch Force	No Contact pressure required
Lifetime (Plastic Overlay)	Minimum 10,000,000 strokes
Sample Rate	Up to 100 samples/sec

INDEX

addressing, 11	OSD Controls, 16
Autostatus, 13	OSD Menu-DVI , 17
baud rate, 10	power-up sequence, 6
Broadcast mode, 8	Rack mounting , 4
Command mode , 7	RS232 commands, 12
connect the cables, 5	RS232 Control , 10
country codes, 9	RS232 pinout, 10
daisy-chaining, 11	Scan mode, 8
Display functions , 16	SerTest, 14
Fn key, 19	Specifications, 22
front panel control, 7	SUN Extra keys , 20
keyboard control, 7	Sun sleep mode, 9
Keyboard LEDs, 19	Switch Control Program , 13
keyboard translation, 20	Telco mount, 4
LEDs, 19	Troubleshooting, 21
Matrix-Y-1 cable, 11	

WARRANTY INFORMATION

The warranty period on this product (parts and labor) is two (2) years from the date of purchase. Please contact Network Technologies Inc at **(800) 742-8324** (800-RGB-TECH) or **(330) 562-7070** or visit our website at <http://www.networktechinc.com/return-policy.html> for information regarding repairs and/or returns. A return authorization number is required for all repairs/returns.