



E-SDS(-CE) E-SDS(-CE)PA SMOKE DETECTION SENSOR

Installation Instruction

The E-SDS(-CE) is a smoke detection sensor intended for connection to an NTI [Enterprise Environment Monitoring System](#) (SYSTEM) for use in detecting smoke in a server cabinet environment. When properly connected, this sensor will provide signals to the SYSTEM that with proper configuration will result in alert messages being sent to the administrator of the SYSTEM. The E-SDS(-CE) has screw terminals for easy user connections.

Options:

- E-SDS-PA also includes a 12VDC (regulated) AC adapter with country-specific line cord (add “-PA” to the model number).
- E-SDS-CE(PA): CE certified (add “CE” to the model number)
- E-SDS-CE-E7: CE certified model with pre-wired 7 foot cable and coupler (can be extended 1000 ft with 24AWG CATx cable) for plug-in to RJ45 Sensor port or wired pigtail to a Digital Input.

| Model | Regulatory Approvals | 12VDC adapter |
|-------------|----------------------|---------------|
| E-SDS | UL | No |
| E-SDS-PA | UL | Yes |
| E-SDS-CE | CE,RoHS | No |
| E-SDS-CEPA | CE,RoHS | Yes |
| E-SDS-CE-E7 | CE,RoHS | No |

Note: The E-SDS(-CE)(PA) is NOT intended to be used as a primary fire and smoke detection device.

Disconnect the Base

Remove the base from the detector head. To remove the base, locate the long and short alignment marks on the side of the base. When the detector head is locked to the base, the alignment mark on the detector head lines up with the long alignment mark on the base (see image below). To release the base, rotate the base to align the shorter alignment mark on the base with the mark on the detector head. Once they are aligned, pull the detector head apart from the base.

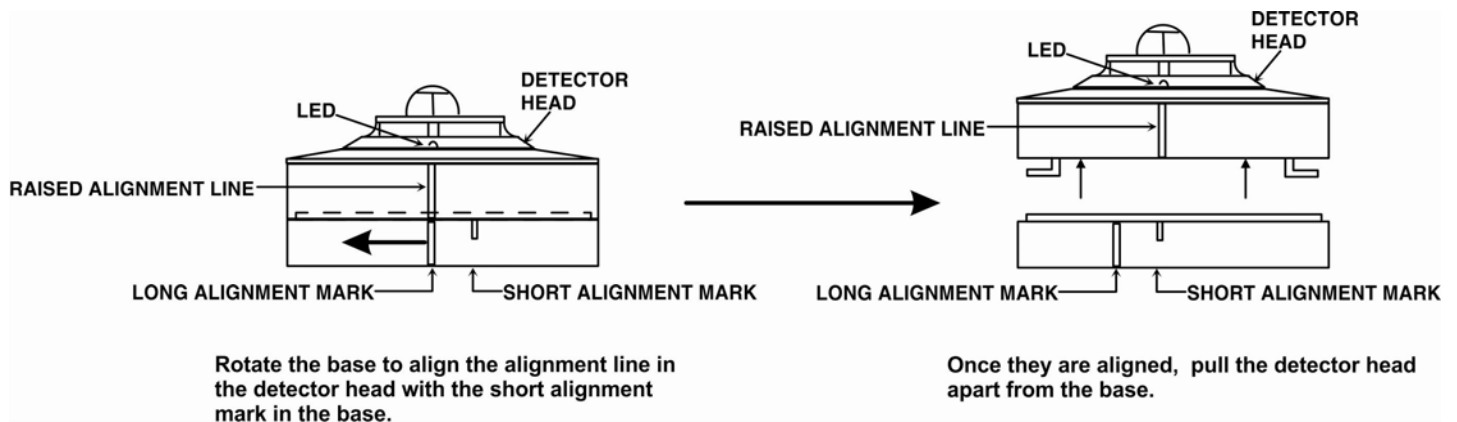

Install the Base

Mount the base of the E-SDS(-CE) where smoke detection is desired.

Switch Contact Connection

1. Connect two 18-22 awg wires (not supplied) to "Digital In" terminals on the E-16D (sets 1-8) , "Digital In" terminals on the E-MINI-LXO, E-2D and E-5D (sets 1-5) or any set of dry contacts on the E-MINI (set 1, 2, 3 or 4).
2. Connect the other end of those two wires to the smoke detection sensor base at terminal set 1-6 and 3-4.

Power Connection

For Model E-SDS(-CE):

1. Connect two 18-22awg wires (not supplied) between the E-16D and the E-SDS(-CE) as shown below.
(Wiring for E-2D and E-5D also shown.)
 - a. Connect one wire between "12V" on the SYSTEM and terminal 2 on the smoke detector.
 - b. Connect the other wire between "⊕" (ground) on the SYSTEM and terminal 5 on the smoke detector.
2. Be sure to tighten terminals to secure each conductor.

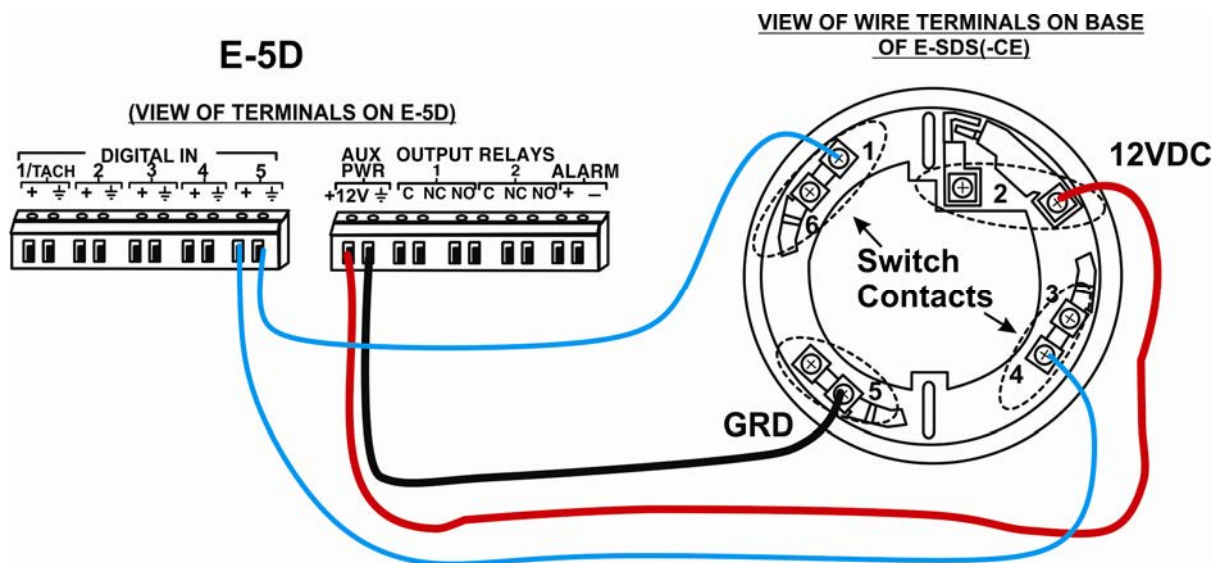
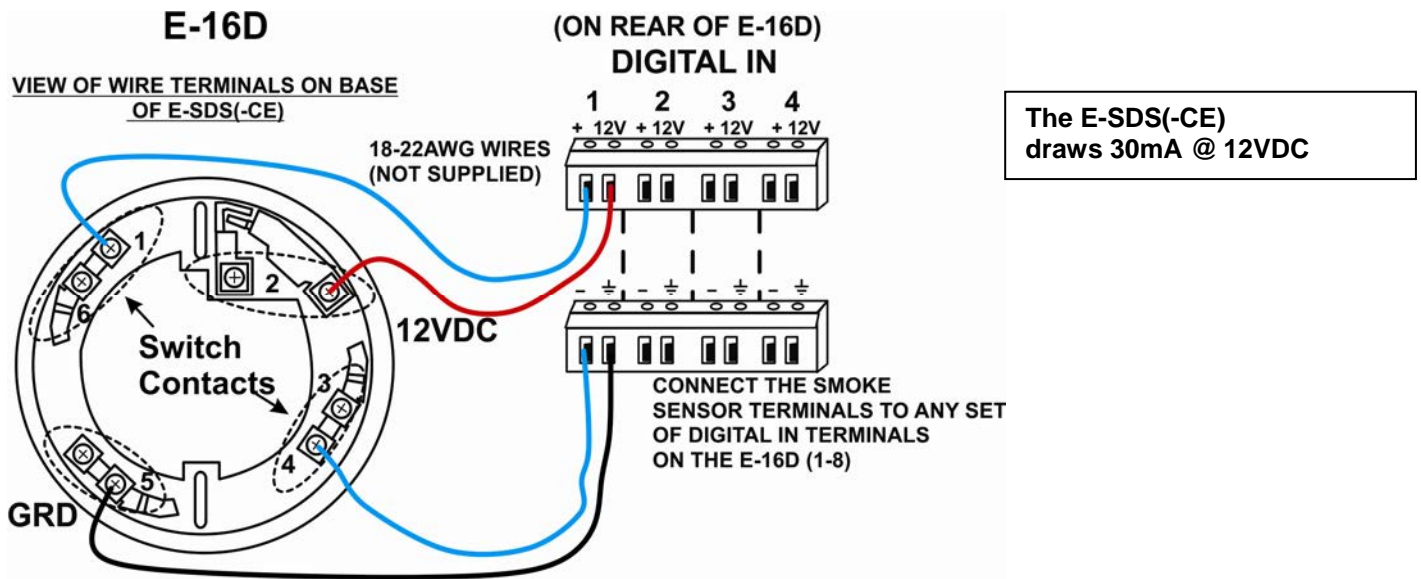

E-2D

VIEW OF TERMINALS ON E-2D

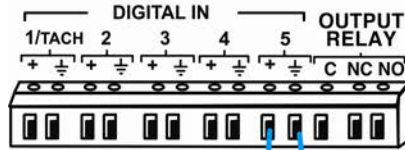

VIEW OF WIRE TERMINALS ON BASE OF E-SDS(-CE)

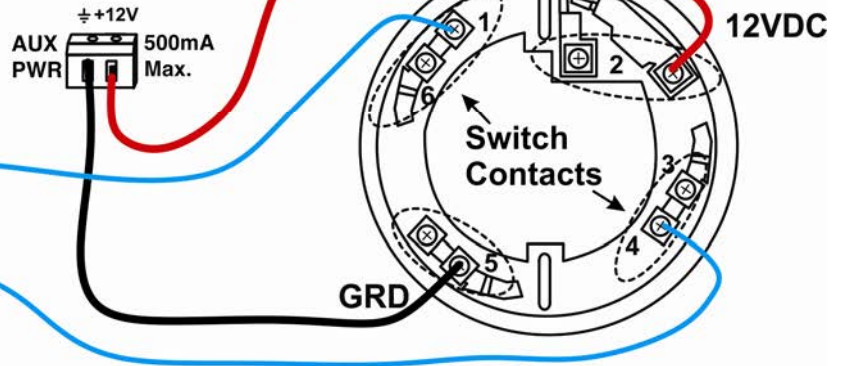

For Model E-SDS(-CE)PA:

When a 12VDC power supply is not available on the SYSTEM (for example, E-MINI and E-MINI-LXO do not include terminals to provide 12VDC power to sensors), model E-SDS(-CE)PA can be used.

1. Connect the AC adapter wire labeled "PLUS 12" to terminal 2 on the smoke detection sensor.
2. Connect the AC adapter wire labeled "NEG" to terminal 5 on the smoke detection sensor.
3. Add a jumper wire between terminals 5 and 6 on the smoke detector.
4. Be sure to tighten terminals to secure each conductor.

E-MINI-LXO

VIEW OF TERMINALS ON E-MINI-LXO

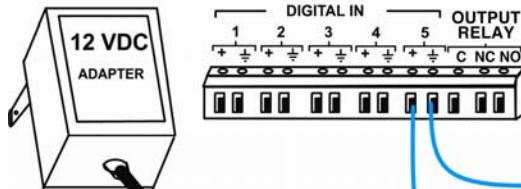

VIEW OF WIRE TERMINALS ON BASE OF E-SDS(-CE)PA

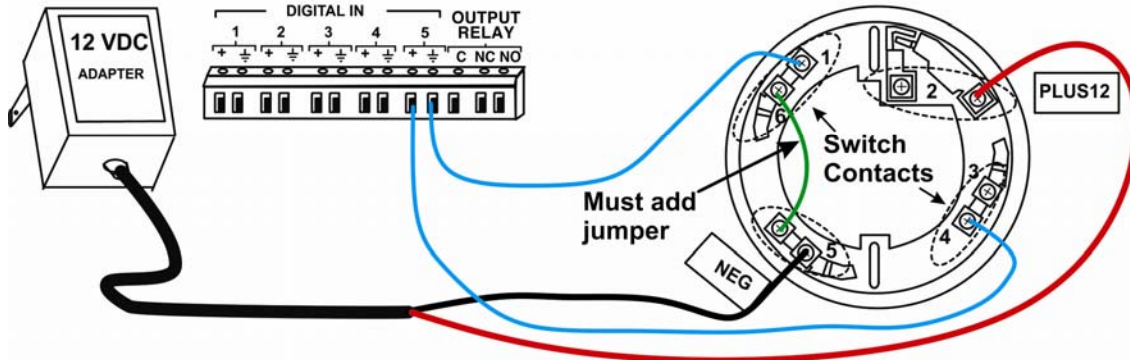

Wired using this method the smoke detector must be manually power-cycled in order to reset it when it goes into alert.

E-MINI-LXO

VIEW OF TERMINALS ON E-MINI-LXO

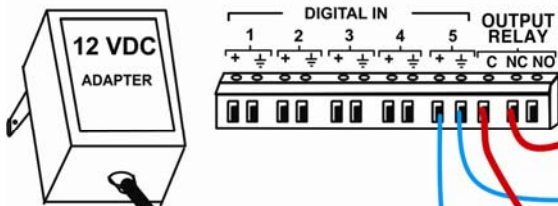

VIEW OF WIRE TERMINALS ON BASE OF E-SDS(-CE)PA

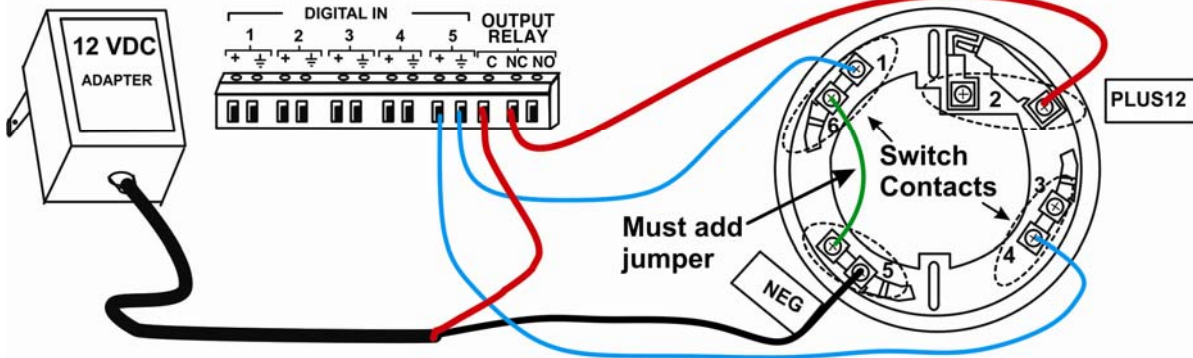

Wired using this method the smoke detector can be power-cycled through the web interface when it is in alert. Make sure that no sensors are configured to activate the output relay when in or out of alert. (See page 7)

ENVIROMUX-MINI

VIEW OF TERMINALS ON ENVIROMUX-MINI

VIEW OF WIRE TERMINALS ON BASE OF ENVIROMUX-SDS-(CE)PA

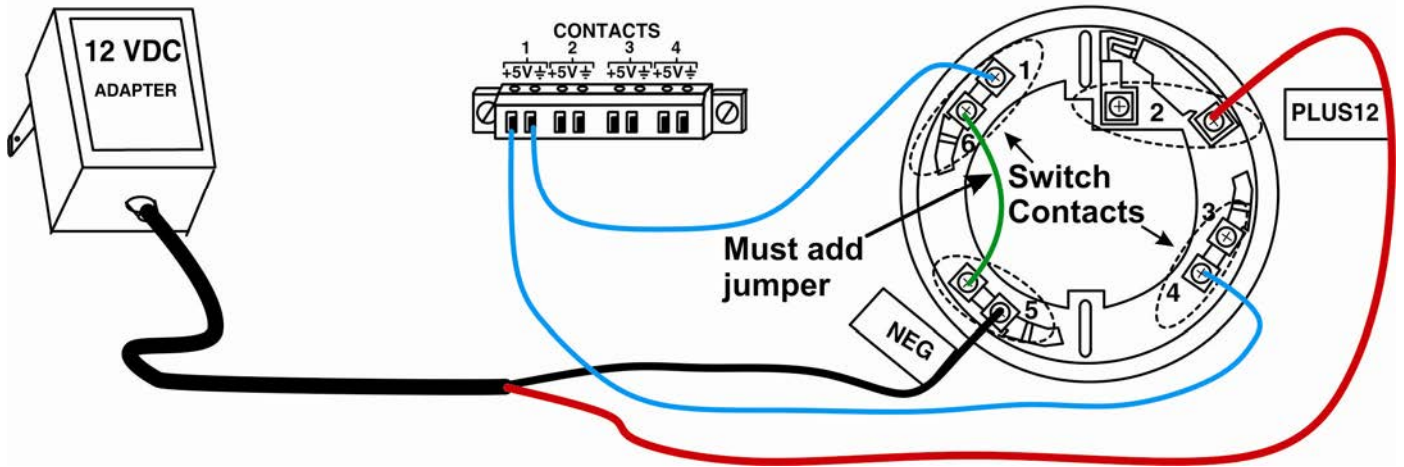

For Model E-SDS-CE-E7:

The E-SDS-CE-E7 includes a 7 foot pre-wired cable with RJ45 connector (wiring shown below) for plug in to either an available RJ45 Sensor port in an E-2D/5D/16D or into a pigtail wired to a Digital Input on an E-2D/5D/16D. No additional power supply is required. The 7 foot cable can be extended to up to 1000 feet using a CAT5 patch cable (minimum 24AWG) using the supplied RJ45 coupler.

Wiring method using a pigtail connected to Digital Input

Front View of E-5D

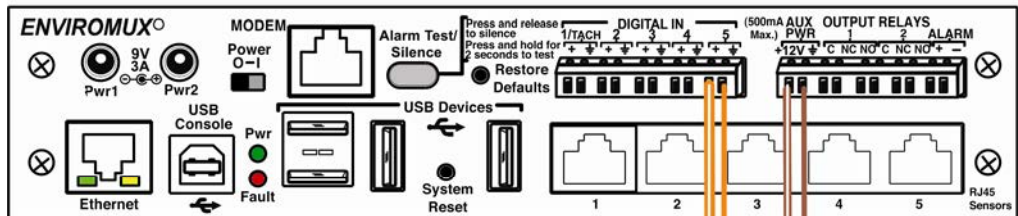

The E-SDS-(CE) draws 30mA @ 12VDC

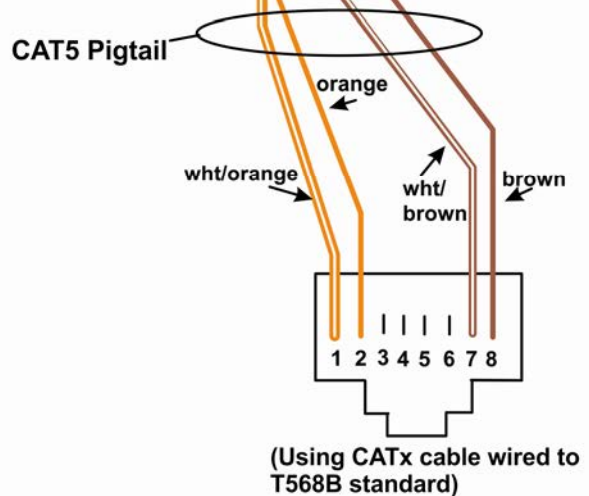

Connection method using a pigtail connected to RJ45 Sensor port

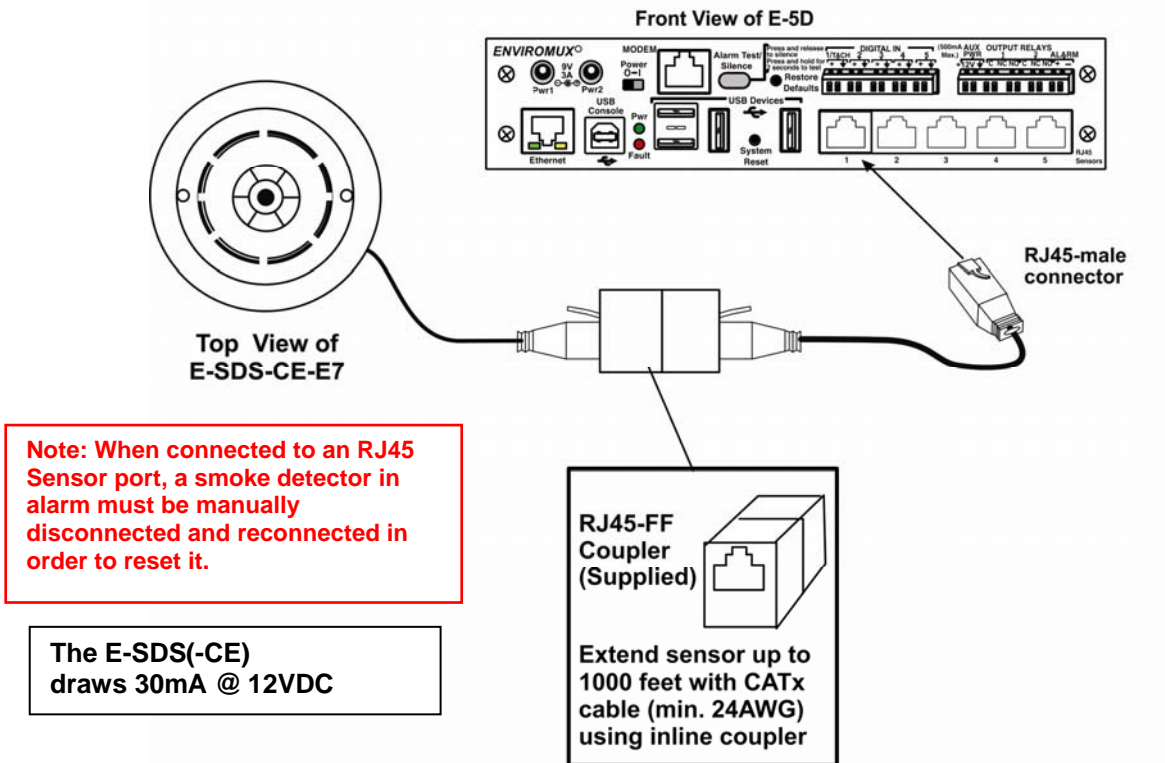

To wire your own CATx patch cable to an E-SDS(-CE) sensor, follow the wiring instruction below.

Wiring when connected to "RJ45 Sensors" socket (Applicable to E-xD Models only)

VIEW OF WIRE TERMINALS ON BASE OF E-SDS(-CE)

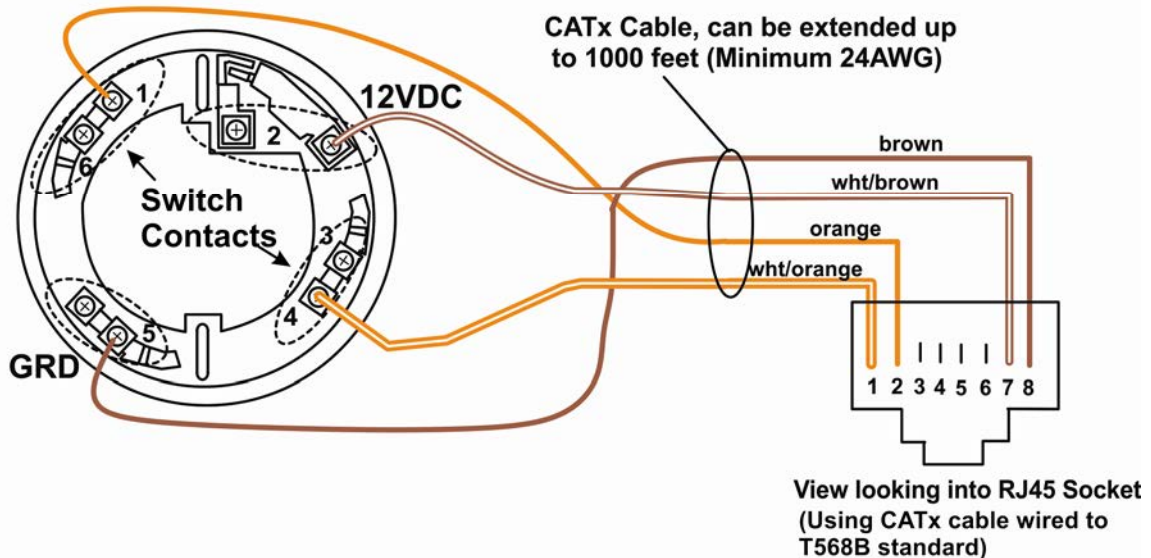

Install the head

1. Align the raised line on the head to the short raised line on the base as shown below.
2. Rotate the head clockwise until the raised line on the head aligns with the longer raised line on the base.

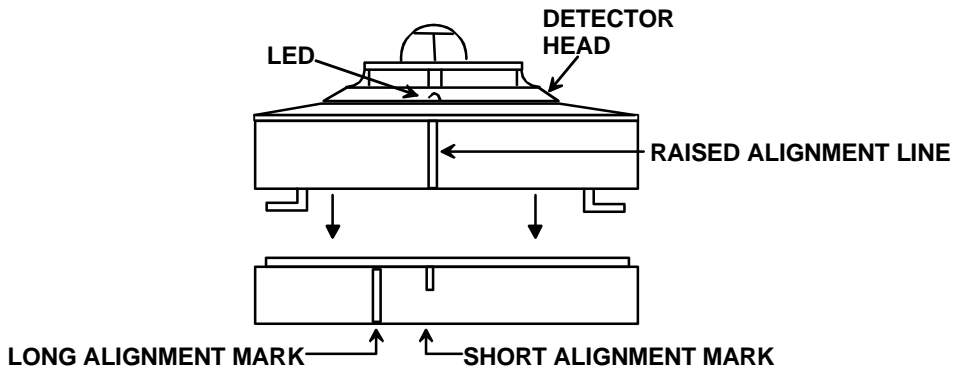

Operation

1. Connect the AC adapter to a 100-240VAC power source. The LEDs on the E-SDS(-CE) will blink red to indicate the sensor is functioning and in status-ready condition. The LEDs will illuminate solid red when smoke is detected.
2. Configure the SYSTEM to report signals from the connected dry contact sensor as smoke detection sensor alerts. (Refer to SYSTEM manual for details on configuration- see also examples on next pages.) When smoke is detected, the switch terminals on the E-SDS(-CE) will close to generate an alert message.

For maintenance and testing instruction, see the instructions that are included from the sensor manufacturer with this kit.



Cycle Sensor Power on E-xD Models

When the smoke detection sensor senses smoke and an alert condition is triggered, in order to reset the smoke detector to a ready state after the presence of smoke has been resolved, the smoke detector must be power-cycled.

A "Cycle Sensor Power" button (below) is provided for each sensor connected to the "Digital In" terminals on the E-16D (locally-connected Digital Inputs only). To momentarily disrupt power to any sensor connected to a Digital Input terminal, click on this button. The 12VDC power will be disrupted to the sensor for 5 seconds and then automatically restored.

Note: On E-5D and -2D, the "Cycle Sensor Power" will cause the "AUX PWR" terminals to cycle power. This will only be effective for the smoke detection sensor if the sensor is being powered from these terminals. If your sensor is powered, for example, from an AC adapter, the "Cycle Sensor Power" button will have no effect on that sensor, but it will still cycle power on the "AUX PWR" terminals, disrupting any device getting power from these terminals for 5 seconds. Keep this in mind if more than one sensor (or device) is being powered from these terminals.

Digital Input #2 Status

Type: Digital Input
Connector:2

Open

Status: Normal

Handle Alert: Dismiss Apply Changes

Last alert was at: Never

[Clear Records](#)

Cycle Sensor Power → Cycle Sensor Power

Configure

Application Note:

A smoke detector connected to an RJ45 Sensor Port does not have "Cycle Sensor Power" button and must be manually disconnected (unplugged) and reconnected in order to reset it. To use this feature, make sure the smoke detector is wired to a Digital Input.

Cycle Sensor Power on E-MINI-LXO

The power to the smoke detector can also be power-cycled on the E-MINI-LXO when wired as shown on the lower image on page 3. If the output relay is used to control power to the smoke detector, the output relay can be manually activated (to open power to the smoke detector) and then deactivated (to restore power to the smoke detector).

When wired in this fashion, make sure that none of the sensors are configured to have the output relay status change to "Active". Both fields (below) must be set to "Inactive". Otherwise, when the relay is active the smoke detector will be powered OFF.

Send alerts for this digital input via SMS

| | |
|---|---|
| Associated Output Relay | None ▾ |
| | Name of the output relay that can be controlled by this digital input |
| Output Relay status on alert | Inactive ▾ |
| | Status of the output relay when going to alert |
| Output Relay status on return from alert | Inactive ▾ |
| | Status of the output relay when returning from alert |

Make sure the Output Relay status for both fields in all sensor configurations is set to "Inactive" if the output relay is used to power the smoke detector.

- Monitoring
 - Summary
 - Sensors
 - Digital Inputs
 - IP Devices
 - Output Relays
 - IP Cameras
- Administration
- Log
- Support
- Logout

Output Relay #1 Status

Type: Output Relay

Inactive

Set Output: Deactivate ▾

To power-cycle the smoke detector using the web interface, set the output to "Activate", click "Apply Changes", then set to "Deactivate" and click "Apply Changes" again.

Digital Input Configuration

| Digital Input Settings | |
|--|--|
| Description | Smoke Detector <small>Descriptive name for the digital input</small> |
| Group | 1 ▾ <small>Select which group the digital input belongs to</small> |
| Normal Status | Open ▾ <small>Select the normal status for the digital input</small> |
| Refresh Rate | 20 <input type="text"/> Sec ▾ <small>The refresh rate at which the digital input view is updated</small> |
| Alert Settings | |
| Disable Alerts | <input type="checkbox"/> <small>Disable alert notifications for this digital input</small> |
| Alert Delay | 1 <input type="text"/> Sec ▾ <small>Duration the digital input must be out of normal status before alert is generated</small> |
| Notify Again Time | 4 <input type="text"/> Hr ▾ <small>Time after which alert notifications will be sent again</small> |
| Notify on return to normal | <input type="checkbox"/> <small>Send a notification when this digital input returns to normal status</small> |
| Auto acknowledge | <input checked="" type="checkbox"/> <small>Automatically acknowledge alert when digital input returns to normal status</small> |
| Enable Syslog Alerts | <input checked="" type="checkbox"/> <small>Send alerts for this digital input via syslog</small> |
| Enable SNMP Traps | <input checked="" type="checkbox"/> <small>Send alerts for this digital input via SNMP traps</small> |
| Enable E-mail Alerts | <input checked="" type="checkbox"/> <small>Send alerts for this digital input via e-mail</small> |
| E-mail Subject | Smoke Detected <small>Subject of e-mails sent for alerts</small> |
| Attach IP camera capture to e-mail | <input checked="" type="checkbox"/> Bench Camera ▾ <small>Attach captured image from selected IP camera to alert e-mail</small> |
| Enable SMS Alerts | <input type="checkbox"/> <small>Send alerts for this digital input via SMS</small> |
| Associated Output Relay | Output Relay #1 ▾ <small>Name of the output relay that can be controlled by this digital input</small> |
| Output Relay status on alert | Inactive ▾ <small>Status of the output relay when going to alert</small> |
| Output Relay status on return from alert | Inactive ▾ <small>Status of the output relay when returning from alert</small> |
| Data Logging | |
| <input type="button" value="Save"/> | |

Example of sensor configuration in E-MINI-LXO

New Sensor Configuration

| | |
|--|---|
| <input type="checkbox"/> Digital Input Settings | |
| Description | <input type="text" value="Smoke Detector"/> Descriptive name for the digital input |
| Group | <input type="text" value="1"/> Select which group the digital input belongs to |
| Normal Status | <input type="text" value="Open"/> Select the normal status for the digital input |
| Refresh Rate | <input type="text" value="20"/> <input type="text" value="Sec"/> The refresh rate at which the digital input view is updated |
| <input type="checkbox"/> Alert Settings | |
| <input type="checkbox"/> Data Logging | |
| <input type="button" value="Save"/> | |
| Alert Simulation | |
| <input type="button" value="Simulate Alert"/> <input type="button" value="Clear Alert"/> | |

Example of sensor configuration in E-16D/-5D/-2D

Dry Contact Sensor Configuration

Name:

| | | |
|--|--|--|
| Thresholds | Alert Timing | |
| Alert when: <input type="text" value="Closed"/> | Alert hysteresis: <input type="text" value="5"/> <input type="text" value="seconds"/> Notify again after: <input type="text" value="1"/> <input type="text" value="hours"/> | <input checked="" type="checkbox"/> Notify on return to normal |

E-mail

Notify addresses:

(separate by commas, max 112 characters)

SNMP

Notify address:

Syslog

Notify address:

Message to send with alerts (optional):

(max 160 characters)

Disable alerts for this sensor

Example of sensor configuration in E-MINI

Warranty Information

The warranty period on this product (parts and labor) is two (2) years from the date of purchase. Please contact Network Technologies Inc at **(800) 742-8324** (800-RGB-TECH) or **(330) 562-7070** or visit our website at <http://www.networktechinc.com> for information regarding repairs and/or returns. A return authorization number is required for all repairs/returns.

COPYRIGHT

Copyright © 2007, 2018 by Network Technologies Inc. All rights reserved. No part of this publication may be reproduced, stored in a retrieval system, or transmitted, in any form or by any means, electronic, mechanical, photocopying, recording, or otherwise, without the prior written consent of Network Technologies Inc, 1275 Danner Drive, Aurora, Ohio 44202.

CHANGES

The material in this guide is for information only and is subject to change without notice. Network Technologies Inc reserves the right to make changes in the product design without reservation and without notification to its users.

Note: The E-SDS(-CE)(PA) is NOT intended to be used as a primary fire and smoke detection device.

Man125 Rev 6/18/18