

ENVIROMUX® Series

E-LDA-LC2 Water Leak Detection Sensor Installation / Operation Instructions



Introduction

The E-LDA-LC2 water leak detection sensor can monitor up to 305 meters (1000 feet) of dual-core water leak sensor cable (E-LDx-y) or chemical leak sensor cable (E-CDx-y). Not only can it be installed with a sensor cable, but is also compatible with other sensors and detectors. Once the sensor detects a leak, E-LDA-LC2 will light up, sound an alarm and cut the power in its internal relay.

It can be used to monitor important places like base stations, warehouses, libraries, museums, and industrial sites etc. for real-time water/chemical leakages. You may also use in conjunction with other equipment like air-treatment devices, refrigeration motors, liquid containers, pump tanks, etc. to help monitor leakage.

Features

- 12VDC 1A power supply (included)
- Manually adjustable sensor sensitivity
- Relay output N.C. / N.O.
- Anti-static and anti-surge protection to ensure reliable operation
- Convenient 35mm DIN guide rail for installation
- Buzzer mute button for silencing an alarm in progress

Installation

Note: Please keep the E-LDA-LC2 in its packaging until you are ready to install it to prevent damage.

Selecting the installation position

The selected installation position should ensure that the sensor is unaffected by natural elements, temperature limits or severe vibrations. The E-LDA-LC2 is designed to be snapped onto a standard 35mm DIN guide rail. Existing electrical or instrumentation cabinets with spare rail space are good mounting locations. It is also possible to install a small section of DIN rail directly on a wall or cabinet surface to mount the E-LDA-LC2 in any location, as long as it does not create a tripping hazard or expose the E-LDA-LC2 to impact damage.

Important: The E-LDA-LC2 is an electronic unit. Take the following precautions to avoid damage to electrical components:

- Handle the unit with care and avoid any shocks and impacts
- Keep dry
- Prior to handling the E-LDA-LC2, avoid exposure to static electricity by touching a nearby piece of grounded equipment or water pipe
- Avoid contact with metal filings, grease, pipe coatings, and other contaminants

Mounting the E-LDA-LC2

- Secure or locate a sufficient length of DIN rail on the desired mounting surface for installation
- Remove the E-LDA-LC2 from its packaging and snap onto the DIN rail with the release tab towards the top. Shown in Figure 1.

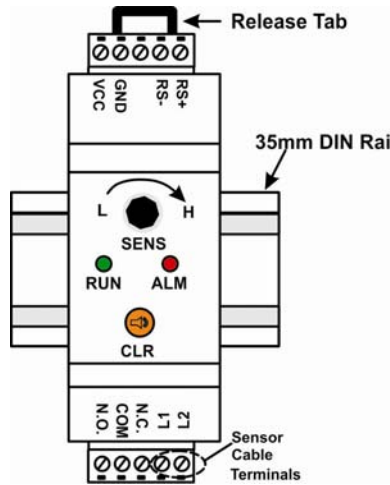

Figure 1: Mount to DIN Rail

Connections for Power

To power the E-LDA-LC2, connect the 12VDC power supply (included) to the “VCC” and “GND” terminal.

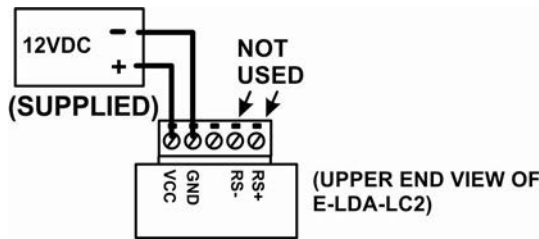

Figure 2: Power connections

Connections for Alarm Relay

The E-LDA-LC2’s output relay contact can be used to control a siren or beacon for local alert or for controlling valves, other devices, or automatic input systems. When wired properly, the relay can also be used to cause the E-xD to send an alert message via email, SMS, SNMP or SYSLOG. The relay only changes state if there is a water leak. The output relay can be normally-open or normally-closed, giving a level of customization. See the table below for configuring alerts.

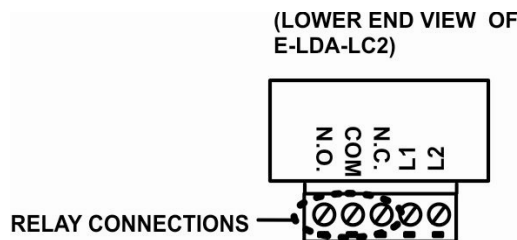

Figure 3: Relay connections

Wiring Combination	Alarm Condition	Output State
N.O.—COM	No alarm	Open
	Alarm	Closed
	Lose power	Open
N.C.—COM	No alarm	Closed
	Alarm	Open
	Lose Power	Closed

Lead Wire Connections for Water Sensor Cable

The E-LDA-LC2 can use the E-LDx-y sensor cables or any other similar sensing cables. Connect the cable as shown below:

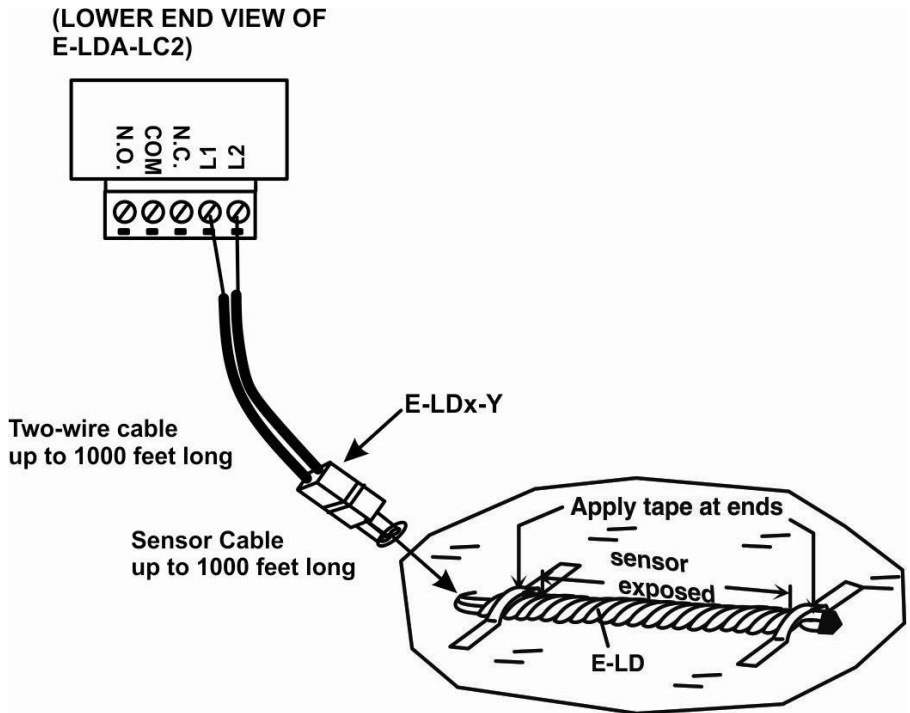

Figure 3: Connect sensing cable

Note: When used with the E-LD-LCx-y Low-Cost Liquid Detection sensor cable the maximum sensor cable length is limited to 600 feet.

Sensitivity Settings

The sensitivity of the E-LDA-LC2 is set at 6 (mid-range) by default. If an adjustment to this sensitivity is necessary it can be manually adjusted.

To adjust sensitivity manually, rotate the knob on the front of the E-LDA-LC2.

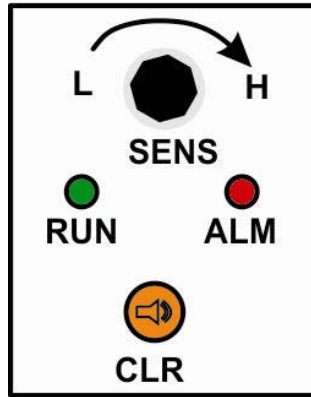

- At the lowest sensitivity, an alarm will be triggered by immersing the water rope in about half an inch of water.
- At medium sensitivity, an alarm will be triggered the moment the water cable touches water.
- At the highest sensitivity setting, an alarm can be triggered by a single spray of water.

Note: The above sensitivity settings are based on using E-LD-LCx-y and E-LDx-y. If the E-CDx-y is used, a higher sensitivity setting to achieve the same results will be needed. (e.g. E-CDx-y requires that the sensing rope be immersed in 1 inch of water to trigger the alarm when set at medium sensitivity.)

LED operational status indications

RUN (green)	Flashing	Operating normally
	Sustained brightness or unlit	Power is not normal or unit is failing
ALARM (red)	On	Presence of leaks
	Off	Absence of leaks

Audible Alarm

When the E-LDA-LC2 detects moisture, the E-LDA-LC2 sounds a built-in 75dB (at 1 foot) audible alarm. This alarm will sound until the moisture is cleared, or until the "CLR" button on the E-LDA-LC2 is pressed. Once pressed, the alarm will not sound again until the sensor state returns to normal and another moisture detection event occurs.

Wiring Diagrams for ENVIROMUX Systems

VIEW OF TERMINALS ON E-16D

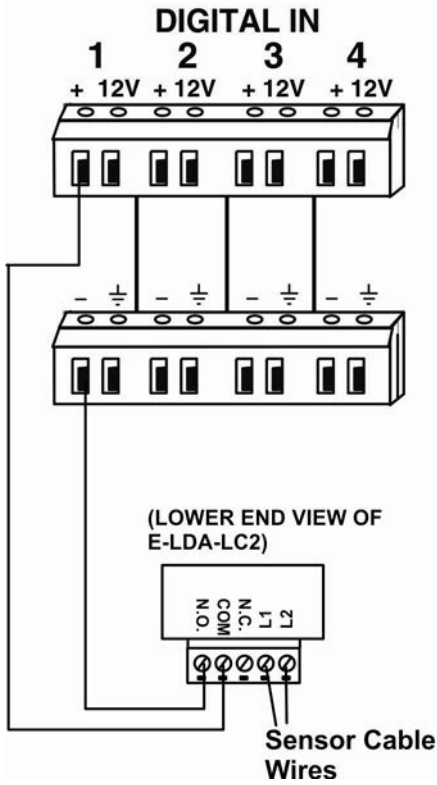

VIEW OF TERMINALS ON E-2D/E-MINI-LXO

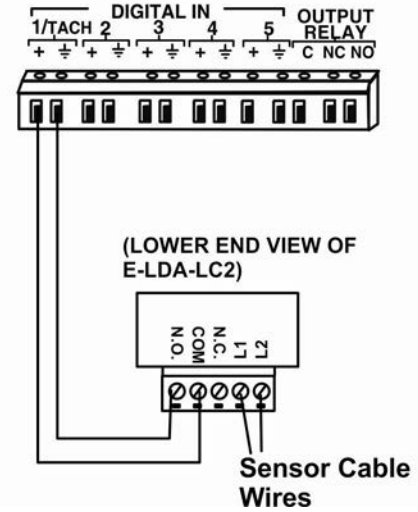

VIEW OF TERMINALS ON E-5D

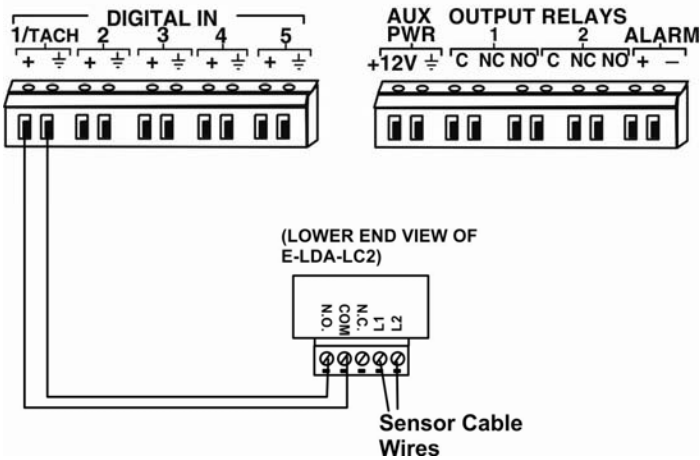

E-MICRO-T/TRHP or E-1W(P)

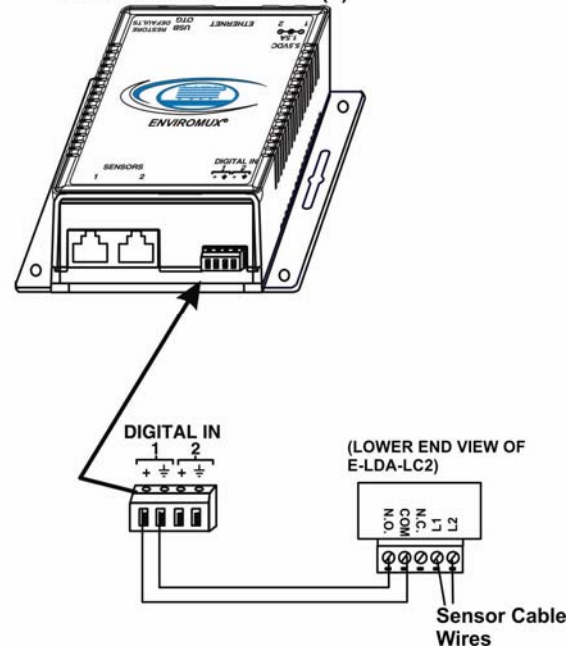

Specifications

Basic Characteristics	
Compatibility	E-LDx-y or similar water leak sensor cables
Sensor cables max length	305 meters (1000 feet) for E-LDx-Y an E-CDx-y 183 meters (600 feet) for E-LD-LCx-y
Accuracy	100%
General	
Storage temperature:	-18°C ~ 60°C (0°F ~ 140°F)
Operating temperature	-0°C ~ 50°C (32°F ~ 122°F)
Operating humidity	5% ~ 95% (non- condensing)
Relay Contacts	Choice of normally-open or normally-closed; alerts for leaks or leaks and sensor failure
Contact Ratings	AC125V, 0.5A, DC24V, 1A
Audible Alarm	75dB (at 1 foot)
Dimensions WxDxH (In.)	2.16x4.45x1.42 (55x113x36mm)
Power supply	100-240VAC@50/60Hz; 12VDC, 1A

Warranty Information

The warranty period on this product (parts and labor) is two (2) years from the date of purchase. Please contact Network Technologies Inc at **(800) 742-8324** (800-RGB-TECH) or **(330) 562-7070** or visit our website at <http://www.networktechinc.com> for information regarding repairs and/or returns. A return authorization number is required for all repairs/returns.

MAN174 REV 10/3/22