



INSTALLATION GUIDE FOR THE E-ACLM-3P480(-L) 3 Phase Power Monitor

INTRODUCTION

The 3-Phase AC Voltage and/or Current Monitor Monitors and reports the True RMS Voltage, RMS Current, Frequency, Active Power and Reactive Power for any 3-phase circuit, such as the power a building consumes. When used in conjunction with an E-16D, -5D or -2D Enterprise Environment Monitoring System (SYSTEM) the user can configure the System to alert users of changing conditions.

Features:

- Reports True RMS Voltage, RMS Current, Active Power and Reactive Power. (Frequency, phase angle, and power factor are also displayed but the reported values are not used for alerts or data logging.)
 - RMS Voltage, RMS Current, Active Power and Reactive Power are each measured and reported on a per phase basis
 - Monitors one single or three-phase circuit (not multiple independent single-phase circuits)
 - Current and power measurements require current transformers (sold separately).
 - Measurement update rate once per second (via software).
- Common applications include: electrical systems, power equipment, generators, remote sites, controlled environment vaults (CEVs), building automation, data center, cabinets, telecom, substations, storage power supplies, communication huts, indoor/outdoor lighting, power distribution, and medical and test equipment.
- Three 2-wire terminal blocks provided for easy attachment of optional current transformers with 16-26AWG wires (sold separately)
 - The use of Split-core current transformers allows installation without disconnecting conductors.
 - Accuracy and range are current transformer-dependent.
- Input primary voltage: Up to 552 VAC RMS, 2000VDC Isolated
 - 4-wire terminal block provided for bare-wire or crimp terminal attachment of primary voltage sample
- Frequency: 50/60Hz
- Maximum primary current: limited only by the current transformer used
- Powered by E-2D/5D/16D (E-ACLM-3P480)
 - E-ACLM-3P480-L is powered by 5VDC 3A AC adapter (supplied)
- Dimensions WxDxH (in): 6.82x3.0x1.725 (173x76x44 mm).
- Supports 24AWG CAT5/5e/6 cable up to 300 ft (91 m).
 - Up to 5280 ft (1609m) is supported by the E-ACLM-3P480-L
- Regulatory approvals: CE, RoHS.
- How to install: voltage inputs tie directly into the line. Caution: should be installed by qualified electricians only.
 - Make sure electrical service is disconnected before making any electrical connections.
- Compatible with [E-FSC](#) Fiber Converter/Extender.
 - Use to extend sensor up to 1.2 miles (2 km) from the ENVIROMUX unit.

Note: The E-xD must be running firmware version 2.43 or later in order to use the E-ACLM-3P480 with it. Refer to the E-xD manual for firmware upgrade instructions as needed.

INSTALLATION

Mount the E-ACLM-3P380 using the mounting ears provided. To use the ears, remove the screws securing the ears to the rear of the E-ACLM-3P480, turn the ears around, and reapply the screws.

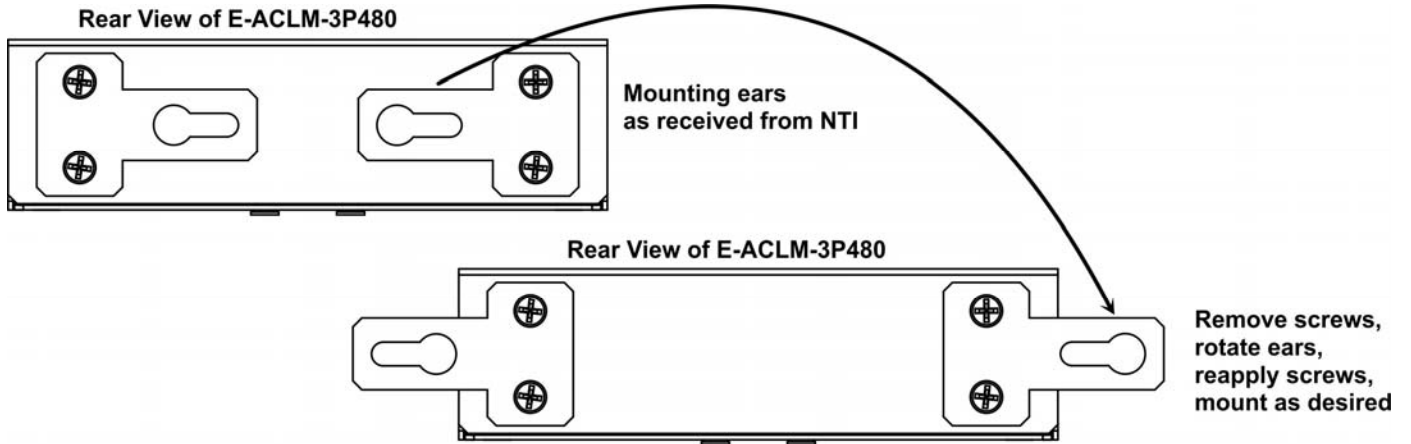

To mount multiple E-ACLM-3P480 in close proximity to the E-16D, install an extension rail kit (NTI E-RL-16D - sold separately) and mount E-ACLM-3P480 as seen in the illustration below.

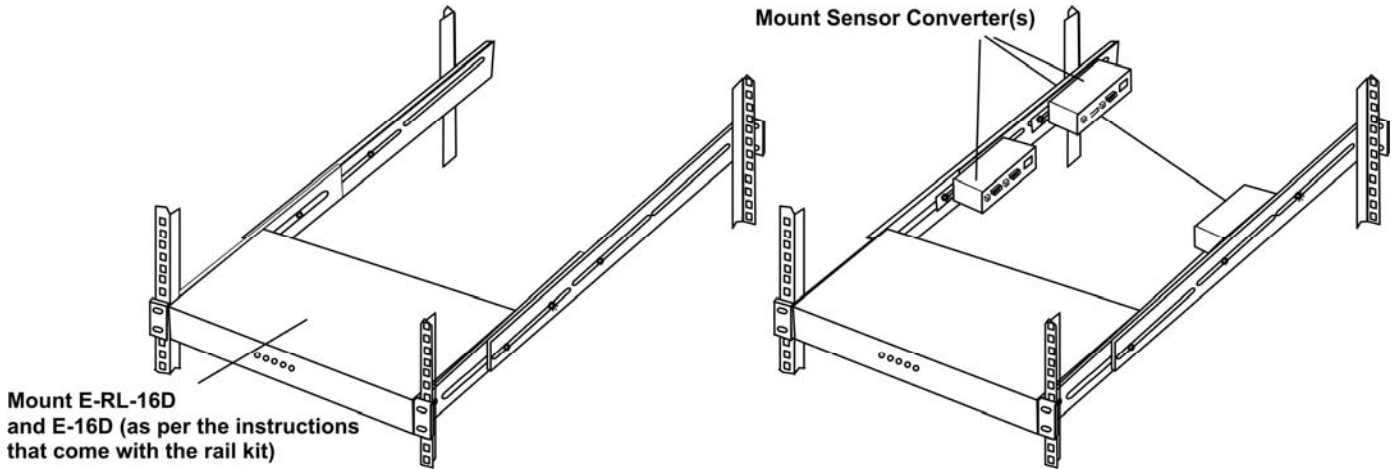

POWER CONNECTION

The E-ACLM-3P480 operates at 5VDC and is powered through the CATx cable connected to the RJ45 Sensor port on the E-16D/5D/2D.

The E-ACLM-3P480-L Extended Range model includes a 5VDC power jack and external power supply. This allows you to mount the E-ACLM-3P480-L up to 5280 feet from the E-xD.

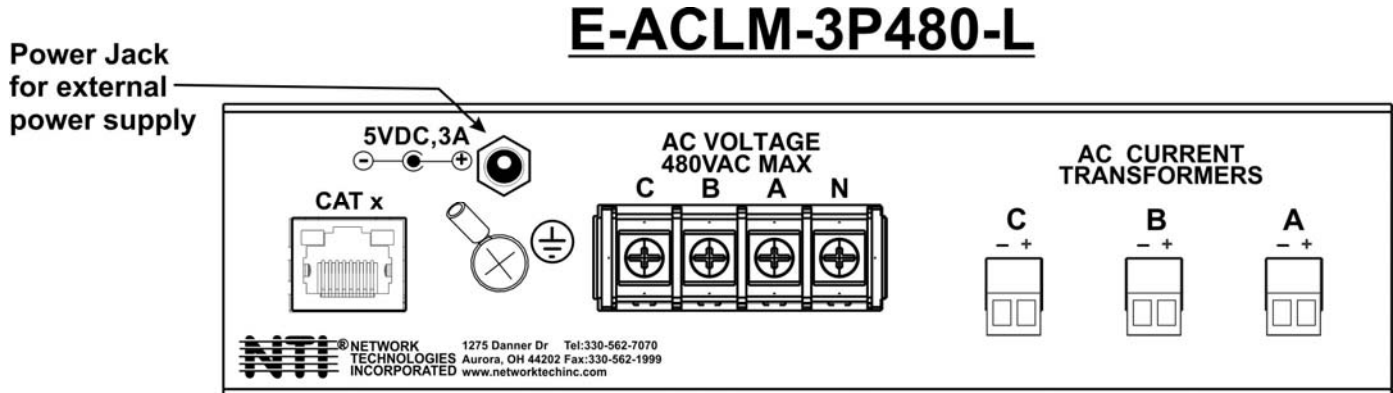

MONITORING CONNECTIONS

Note: To prevent damage to the voltage source or the Sensor Adapter proper polarity must be observed when making connections.

1. At the "AC VOLTAGE" terminal block, connect a voltage source to be monitored using 16-24AWG wire rated for at least 600 volts.
2. If current sensing is desired, install current transformers (sold separately) to the circuit(s) to be monitored. Then connect the attached 2-wire cables to the sensor at one of the "AC CURRENT TRANSFORMER" terminals.

A chassis (earth) ground terminal is provided for application of a safety earth ground wire.

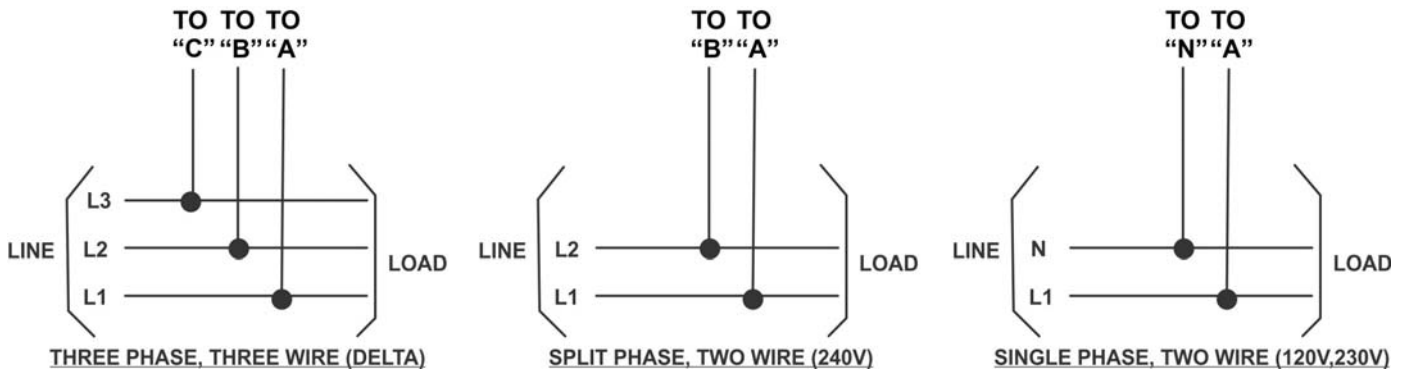
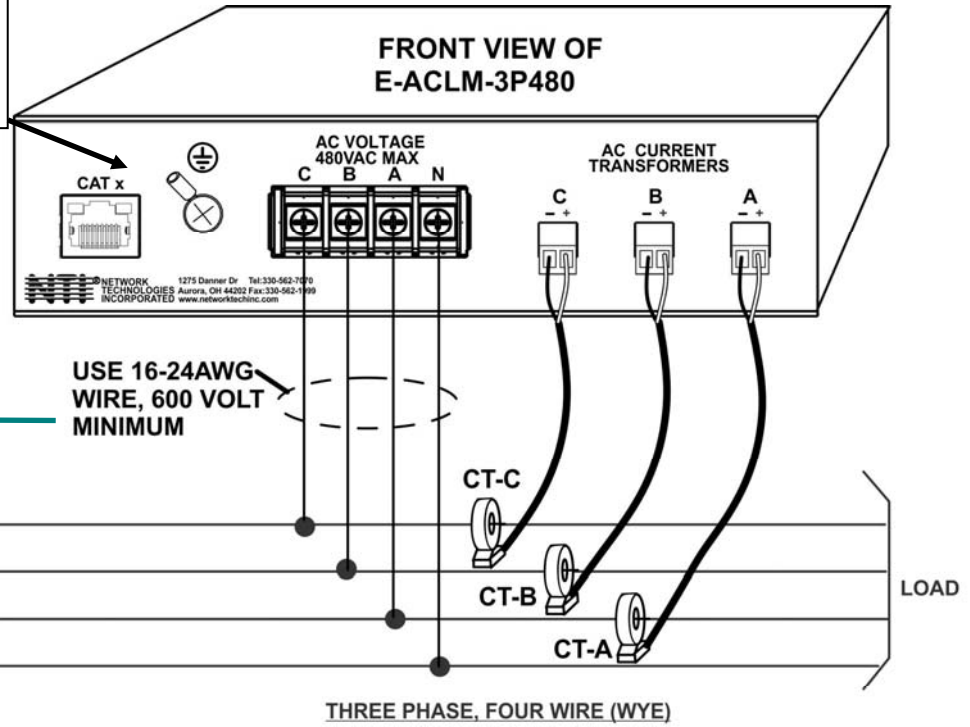

Other similar products require fuse protection on the wires for AC Line Voltage connection because they use those connections as a source of power. The E-ACLM-3P480 gets all power to operate from the E-xD through the CATx cable and only uses the AC Line Voltage connections for high-impedance sensing.

TIP: A single current transformer can be used to measure current at different ranges. By passing a wire through the sensor loop repeatedly (looping the wire around), the range of the unit will be divided by the number of times the wire passes through. For a 100A sensor, for example, two passes will reduce it by 100/2 (range of 0-50A), three passes will reduce it by 100/3 (range of 0-33A), and so on. See example below. If you need to increase the sensitivity of your current transformer, this is a way to do so. Be sure to adjust the value of your “Nominal Range” when configuring the “RMS AC Current” (page 6) in accordance with the adjusted range of the current transformer.

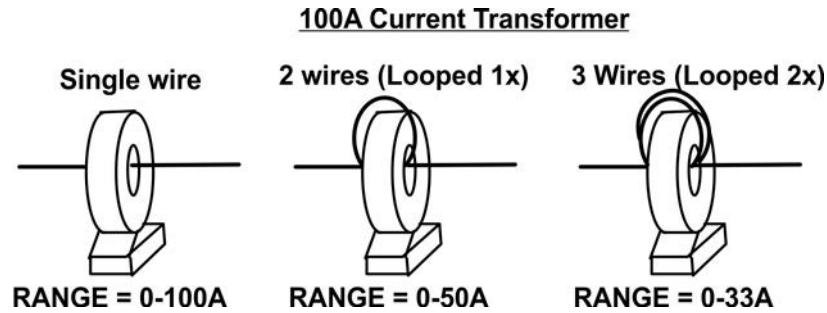

3. Connect a 24AWG CAT5/5e/6 patch cable (up to 300 feet long) between the “Cat x” port on the E-ACLM-3P480 and an “RJ45 Sensor” port on the SYSTEM. (The use of smaller gauge CATx cabling will result in shorter distances that can be spanned.)

Note: The CAT5/5e/6 patch cable used between the E-ACLM-3P480-L can be up to 5280 feet in length, provided the 5VDC external power supply (included) is used.

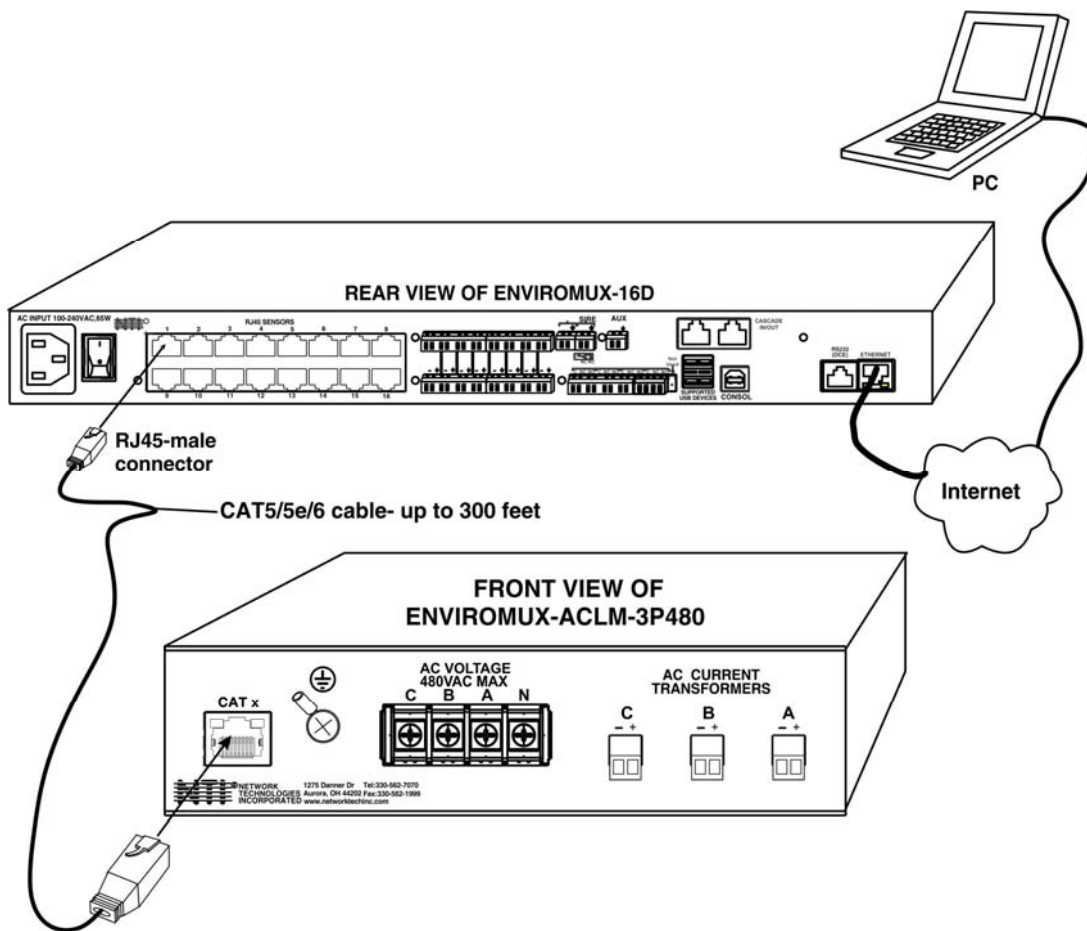

4. Configure the SYSTEM to react to changes in the voltage and/or current from the source, as desired. See examples on the following pages.

CONFIGURATION

Sensors					
Conn.	Description	Type	Value	Status	Action
1	E-MNG-T1 Phase A Voltage	RMS AC Voltage	113.7V	Normal	View Edit Delete
1	E-MNG-T1 Phase A Current	RMS AC Current	6.1A	Normal	View Edit Delete
1	E-MNG-T1 Phase B Voltage	RMS AC Voltage	113.8V	Normal	View Edit Delete
1	E-MNG-T1 Phase B Current	RMS AC Current	6.2A	Normal	View Edit Delete
1	Sensor #1.3b	Active Power	702.2W	Normal	View Edit Delete
1	Sensor #1.4b	Reactive Power	-29.8VAR	Normal	View Edit Delete
1	E-MNG-T1 Phase C Voltage	RMS AC Voltage	113.8V	Normal	View Edit Delete
1	E-MNG-T1 Phase C Current	RMS AC Current	6.2A	Normal	View Edit Delete
1	Sensor #1.3c	Active Power	700.0W	Normal	View Edit Delete
1	Sensor #1.4c	Reactive Power	-21.6VAR	Normal	View Edit Delete

When an E-ACLM-3P480 is connected to the ENVIROMUX, the summary page (above) will update with 3 sets of 4 different sensor types, RMS AC Voltage, RMS AC Current, Active Power and Reactive Power. The sensor is plugged into RJ45 Sensor port #2 in this example. Numbers "1a", "1b", "1c" correspond to the letters A-C on the E-ACLM-3P480 for connected AC Voltage and Current sources. Click on the Sensor in the Description column (or "View" under Action) and display the status page for each sensor. (Below). In order to better define the sensor on the Summary Page, in SNMP traps, or in an MIB browser, click on the "Edit" link to open the sensor configuration page and configure the sensor.

Sensor #1.1a Status

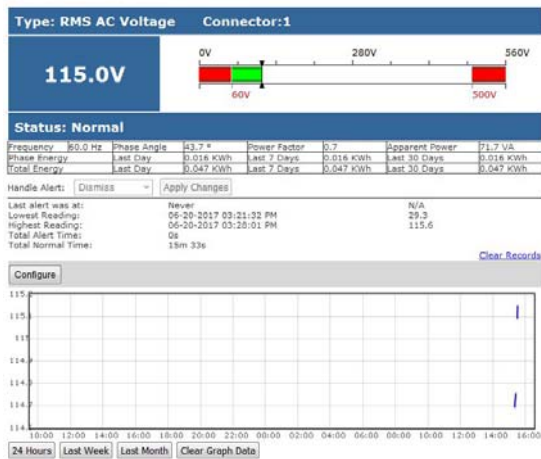

Sensor #1.2a Status

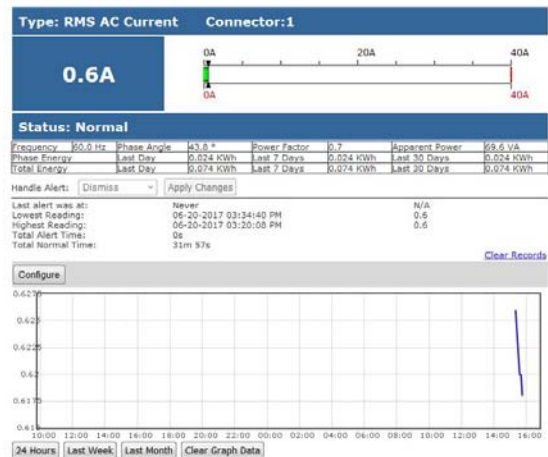

Sensor #1.3a Status



Sensor #1.4a Status

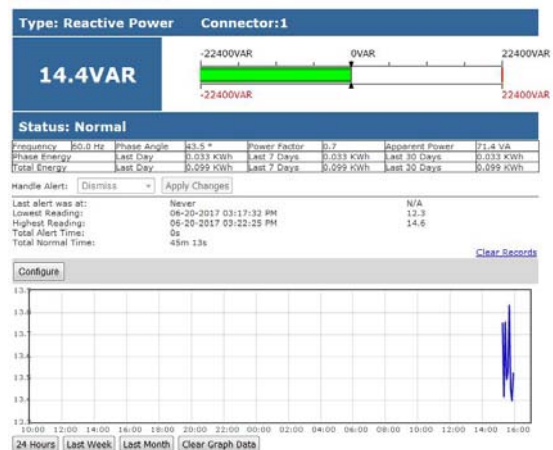

Click on the "Configure" button on any Status Page to display the Configuration page for any sensor.

E-MNG-T1 Phase A Voltage Configuration (Type: RMS AC Voltage)

Sensor Settings	
Description	E-MNG-T1 Phase A Voltage Descriptive name for the sensor
Min. Level	0.0 Min. supported value for the sensor
Max. Level	480.0 Max. supported value for the sensor
3-Phase Configuration	Wye Select the 3-Phase configuration
Min. Non-Critical Threshold	0.0 Min. threshold below which indicates a non-critical alert condition
Max. Non-Critical Threshold	240.0 Max. threshold above which indicates a non-critical alert condition
Min. Critical Threshold	0.0 Min. threshold below which indicates an alert condition
Max. Critical Threshold	265.0 Max. threshold above which indicates an alert condition
Refresh Rate	10 Sec The refresh rate at which the sensor view is updated
Group Settings	
Schedule Settings	
Non-Critical Alert Settings	
Critical Alert Settings	
Data Logging	
<input type="button" value="Save"/>	
Alert Simulation	
<input type="button" value="Simulate Alert"/> <input type="button" value="Clear Alert"/>	

Select between Wye and Delta configurations

When you set this configuration to Wye or Delta for one phase (A, B or C), it will be automatically changed for the other two phases as well.

E-MNG-T1 Phase A Current Configuration (Type: RMS AC Current)

Sensor Settings	
Description	E-MNG-T1 Phase A Curren Descriptive name for the sensor
Sensor Unit	A Measurement unit
Nominal Range	10.000000 Hall-Effect transducer rated current
Min. Non-Critical Threshold	0.0 Min. threshold below which indicates a non-critical alert condition
Max. Non-Critical Threshold	10.0 Max. threshold above which indicates a non-critical alert condition
Min. Critical Threshold	0.0 Min. threshold below which indicates an alert condition
Max. Critical Threshold	10.0 Max. threshold above which indicates an alert condition
Refresh Rate	10 Sec The refresh rate at which the sensor view is updated
Group Settings	
Schedule Settings	
Non-Critical Alert Settings	
Critical Alert Settings	
Data Logging	
<input type="button" value="Save"/>	
Alert Simulation	
<input type="button" value="Simulate Alert"/> <input type="button" value="Clear Alert"/>	

Whatever value you set the current range to for one phase (A, B or C), it will be automatically changed for the other two phases as well.

If the Nominal Range is set to 0, then the Active Power and Reactive Power values will also be reported as 0.

Sensor #1.3c Configuration (Type: Active Power)

Sensor Settings	
Description	<input type="text" value="Sensor #1.3c"/> Descriptive name for the sensor
Min. Level	<input type="text" value="0.0"/> Min. supported value for the sensor
Max. Level	<input type="text" value="4800.0"/> Max. supported value for the sensor
Min. Non-Critical Threshold	<input type="text" value="0.0"/> Min. threshold below which indicates a non-critical alert condition
Max. Non-Critical Threshold	<input type="text" value="4800.0"/> Max. threshold above which indicates a non-critical alert condition
Min. Critical Threshold	<input type="text" value="0.0"/> Min. threshold below which indicates an alert condition
Max. Critical Threshold	<input type="text" value="4800.0"/> Max. threshold above which indicates an alert condition
Refresh Rate	<input type="text" value="10"/> <input type="text" value="Sec"/> <input type="button" value="v"/> The refresh rate at which the sensor view is updated
Group Settings	
Schedule Settings	
Non-Critical Alert Settings	
Critical Alert Settings	
Data Logging	
<input type="button" value="Save"/>	
Alert Simulation	
<input type="button" value="Simulate Alert"/> <input type="button" value="Clear Alert"/>	

Sensor #1.4a Configuration (Type: Reactive Power)

Sensor Settings	
Description	<input type="text" value="Sensor #1.4a"/> Descriptive name for the sensor
Min. Level	<input type="text" value="-4800.0"/> Min. supported value for the sensor
Max. Level	<input type="text" value="4800.0"/> Max. supported value for the sensor
Min. Non-Critical Threshold	<input type="text" value="-4800.0"/> Min. threshold below which indicates a non-critical alert condition
Max. Non-Critical Threshold	<input type="text" value="4800.0"/> Max. threshold above which indicates a non-critical alert condition
Min. Critical Threshold	<input type="text" value="-4800.0"/> Min. threshold below which indicates an alert condition
Max. Critical Threshold	<input type="text" value="4800.0"/> Max. threshold above which indicates an alert condition
Refresh Rate	<input type="text" value="10"/> <input type="text" value="Sec"/> <input type="button" value="v"/> The refresh rate at which the sensor view is updated
Group Settings	
Schedule Settings	
Non-Critical Alert Settings	
Critical Alert Settings	
Data Logging	
<input type="button" value="Save"/>	
Alert Simulation	
<input type="button" value="Simulate Alert"/> <input type="button" value="Clear Alert"/>	

The sensor settings are the same as any other sensor configuration (page 39 of the E-xD manual). Refer to the SYSTEM manual for details and descriptions of all the configuration criteria.

SNMP INFORMATION

When looking for the sensor information in a MIB file using SNMP, you must look for it in each of three locations:

- External Sensors,
- Aux Sensors, and
- Aux2 Sensors.

There are 12 different sensors that report from the E-ACLM-3P480 and some will be found in each of these locations.

TECHNICAL SPECIFICATIONS

Description	Specification
Polling rate	1Sa/s
AC Voltage Range	0-552VAC , 2000VDC Isolated
AC Resolution	0.1VAC
Accuracy	± 3VAC
Current Measurement	Requires Current Transformer (sold separately)
Power: E-ACLM-3P480 E-ACLM-3P480-L	5VDC from E-xD Sensor port 120VAC or 240VAC at 50 or 60Hz-5VDC/3A AC Adapter
Current Transformer Input	.1AAC resolution
Current Range	Limited by current transformer used
Current Draw	62mA
CATx cable range: E-ACLM-3P480 E-ACLM-3P480-L	300 Ft (91m) 5280 Ft (1609m)
Size (In.) W x D x H	6.83 x 3.0 x 1.75
Regulatory Approvals	CE, RoHS

COPYRIGHT

Copyright © 2009-2018 Network Technologies Inc All rights reserved. No part of this publication may be reproduced, stored in a retrieval system, or transmitted in any form or by any means, electronic, mechanical, photocopying, recording, or otherwise, without the prior written consent of Network Technologies Inc, 1275 Danner Drive , Aurora, OH 44202.

CHANGES

The material in this guide is for information only and is subject to change without notice. Network Technologies Inc reserves the right to make changes in the product design without reservation and without notification to its users.

WARRANTY INFORMATION

The warranty period on this product (parts and labor) is two (2) years from date of purchase. Please contact Network Technologies Inc at (800) 742-8324 or 330-562-7070 for information regarding repairs and/or returns. A return authorization number is required for all repairs/returns.

MAN270 Revised 4/4/2018