



NTI® NETWORK
TECHNOLOGIES
INCORPORATED

1275 Danner Dr Tel:330-562-7070
Aurora, OH 44202 Fax:330-562-1999
www.networktechinc.com

XTENDEX® Series

ST-C5HDMI-300

300 FOOT HDMI DIGITAL VIDEO/AUDIO EXTENDER

Installation and Operation Manual



TRADEMARK

XTENDEX is a registered trademark of Network Technologies Inc in the U.S. and other countries.

COPYRIGHT

Copyright © 2008 by Network Technologies Inc. All rights reserved. No part of this publication may be reproduced, stored in a retrieval system, or transmitted, in any form or by any means, electronic, mechanical, photocopying, recording, or otherwise, without the prior written consent of Network Technologies Inc, 1275 Danner Drive, Aurora, Ohio 44202.

CHANGES

The material in this guide is for information only and is subject to change without notice. Network Technologies Inc reserves the right to make changes in the product design without reservation and without notification to its users.

CE Statement

The ST-C5HDMI-300 has been tested to the European Standards EN55022:1998+A1:2000+A2:2003 and EN55024:1998+A1:2001+A2:2003 has been found to be in compliance with the council EMC directive 89/336/EEC.

Federal Communications Commission Radio Frequency Interference Statement

This device complies with Part 15 of the FCC rules. Operation is subject to the following two conditions:

- (1) This device may not cause harmful interference
- (2) This device must accept any interference received, including interference that might cause undesired operation.

This device complies with Part 15 of the FCC rules. This equipment has been tested and found to comply with the limits for a Class A digital device, pursuant to Part 15 of the FCC rules. These limits are designed to provide reasonable protection against harmful interference when the equipment is operated in a commercial environment.

Warning: This equipment generates, uses and can radiate radio frequency energy, and, if not installed and used in accordance with the instruction manual, may cause harmful interference to radio communications.

TABLE OF CONTENTS

Introduction.....	1
Materials.....	1
Features and Functions.....	2
Limitations.....	3
Preparation for Installation.....	3
Installation.....	4
Installing The Remote Unit.....	4
Installing The Local Unit.....	4
Connect the CAT5 Cables.....	5
Plug-in and Boot Up.....	5
Technical Specifications.....	6
Interconnection Cable Wiring Method.....	6
Troubleshooting.....	7
Warranty Information.....	7

TABLE OF FIGURES

Figure 1- Connect the extended video display to the Remote Unit.....	4
Figure 2- Connect the XTENDEX Local Unit to the source.....	4
Figure 3- Connect CAT5 cables.....	5
Figure 4- Connect the AC adapter to the Remote Unit.....	5
Figure 5- LEDs on Remote Unit.....	5
Figure 6- View looking into RJ45 female.....	6

INTRODUCTION

The XTENDEX Series CAT5 HDMI Digital Video / Audio Extender (XTENDEX) is designed to enable the video and audio output from one digital video/audio source to be viewed and heard by a remote user. The remote HDMI video/audio device can be located as much as 300 feet away from an HDMI video/audio source via Category 6 twisted-pair cable.

The XTENDEX Series Extender is extremely simple to install and has been thoroughly tested to insure reliable performance. Through the use of CAT5/5e/6 (CAT5) cable it is possible to economically increase the flexibility of a computer system. Here are some of the features and ways this can benefit any workplace:

- Allows the placement of an HDMI-enabled monitor in a location where only these parts are needed without having the video/audio source there too, taking up valuable space
- Allows digital video/audio to be viewed and heard by a remote user (up to 300 feet away)
- Provides crisp and clear computer resolution to 1920 x 1200 and HDTV resolutions to 1080i (see page 6 for more details)
- Transmits HDMI signal over two CAT5 cables.
- Only one power supply is necessary to power both the Local and Remote units.
- Supports an HDMI or DVI monitor.
- Supports 480i/p, 576i/p, 720i/p, and 1080i, video formats
- HDCP Compliant
- Supports the DDC2B protocol.
- Supports digital audio format, such as LPCM/Dolby-AC3/DTS7.1/DSD

MATERIALS

Materials Included with this kit:

- ✓ NTI XTENDEX Local Unit
- ✓ NTI XTENDEX Remote Unit
- ✓ 120VAC or 240VAC at 50 or 60Hz-5VDC/2.0A AC Adapter
- ✓ CD containing a pdf of this owner's manual

Additional materials may be required but are not supplied:

- CAT5 unshielded twisted-pair cables terminated with RJ45 connectors wired straight thru- pin 1 to pin 1, etc. (see pg. 6 for proper EIA/TIA 568 B wiring method)
- HDMI male-male cable to connect the monitor to the Remote unit (Order NTI # HDMI-xx-MM where xx=3, 6, 9, or 14 foot cable).
- DVI-D male to HDMI-A male single link cable to connect a DVI source or display (Order NTI # DVI-HDMI-xx-MM where xx=3, 6, 10, or 15 foot cable)

Contact your nearest NTI distributor or NTI directly for all of your KVM needs at 800-RGB-TECH (800-742-8324) in US & Canada or 330-562-7070 (Worldwide) or at our website at <http://www.networktechinc.com> and we will be happy to be of assistance.

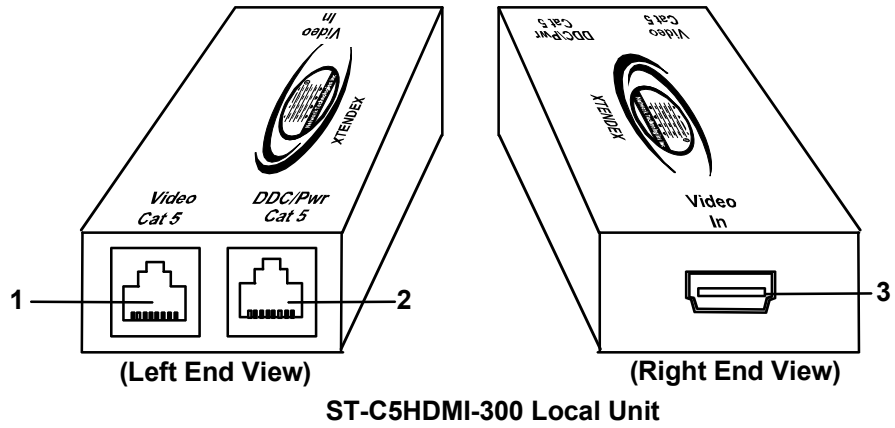

ST-C5HDMI-300 Local Unit

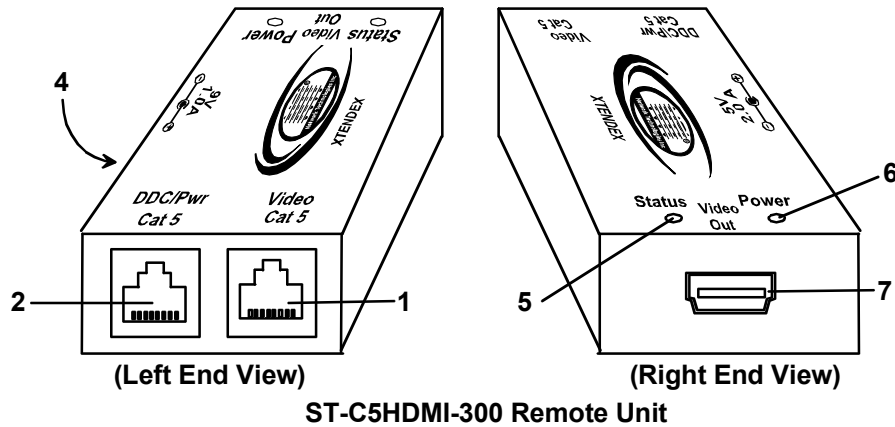

ST-C5HDMI-300 Remote Unit

FEATURES AND FUNCTIONS

1. Video Cat5- RJ45 connector- for connecting the CAT5 cable to carry the video signal between the Local and Remote units
2. DDC/Pwr - RJ45 connector- for connecting the CAT5 cable between the Local and Remote units to carry DDC data from the remote video display and to carry power to the Local unit.
3. Video In- HDMI female video connector- for connecting an HDMI cable between the Local Unit and the video source
4. 5VDC- 2.0A- connection jack for the AC adapter
5. Status LED- blue status indicator- illuminates blue when connection has been made with the video/audio source
6. Power LED- red power indicator- illuminates when power has been supplied to the unit
7. Video Out- HDMI female video connector- for connecting the remote HDMI display device

LIMITATIONS

- Hot-plugging of monitors is supported provided monitors were originally connected at power-up.
- The use of CAT5 stranded cabling will reduce the maximum distance and resolution.

PREPARATION FOR INSTALLATION

- Locations should be chosen for the monitor that also has space to connect the Remote unit within the distance provided by the cables. If extension cables are needed, contact NTI for the cables required.
- The CAT5 cables must be run to the locations where the Remote and Local units will be connected. Be careful to route the cables away from any sources of magnetic fields or electrical interference that might reduce the quality of the video signal (i.e. AC motors, welding equipment, fluorescent lighting, etc.).
- All cables should be installed in such a way that they do not cause stress on their connections to the equipment. Extended lengths of cable hanging from a connection may interfere with the quality of that connection. Secure cables as needed to minimize this.
- Properly shut down and disconnect the power from the video source and monitor to be separated. If other equipment is involved whose connections are being interrupted, be sure to refer to the instruction manuals for that equipment for proper disconnection and reconnection procedures before proceeding.

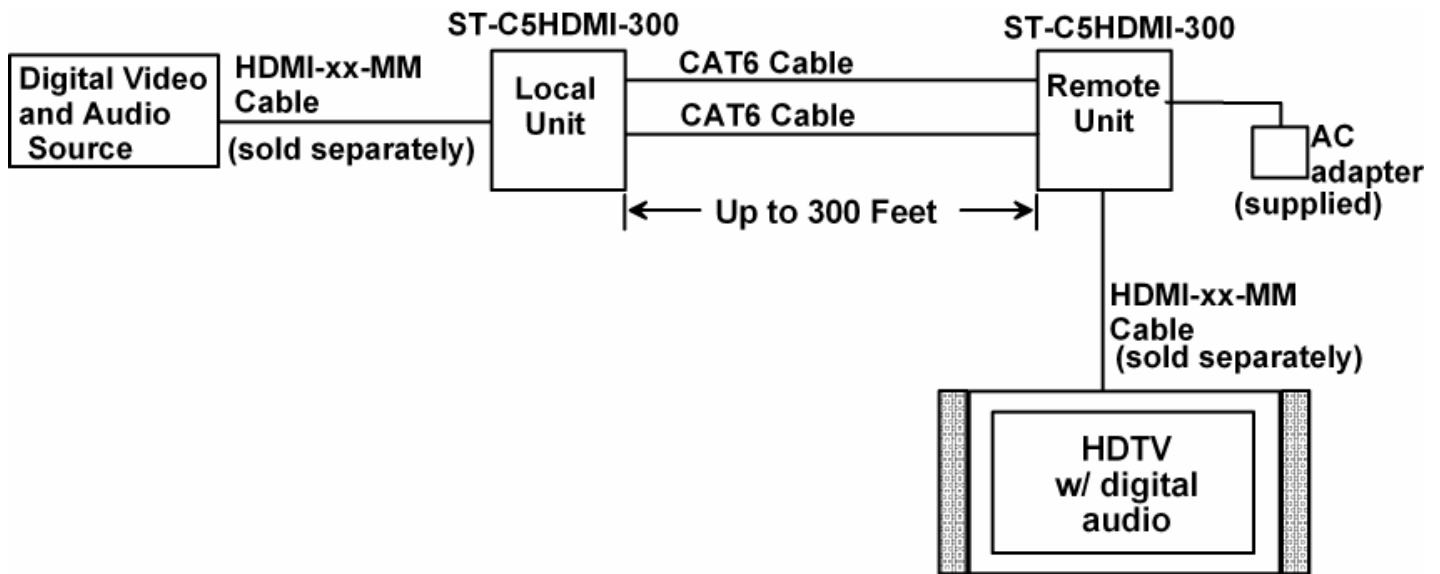

TYPICAL APPLICATION

INSTALLATION

Installing The Remote Unit

1. Position the Remote Unit such that the CAT5 cable and the monitor cables can each reach the Remote Unit without putting strain on the cables.
2. Connect the HDMI-enabled monitor cable to the female HDMI video connector labeled "Video Out" on the Remote Unit.

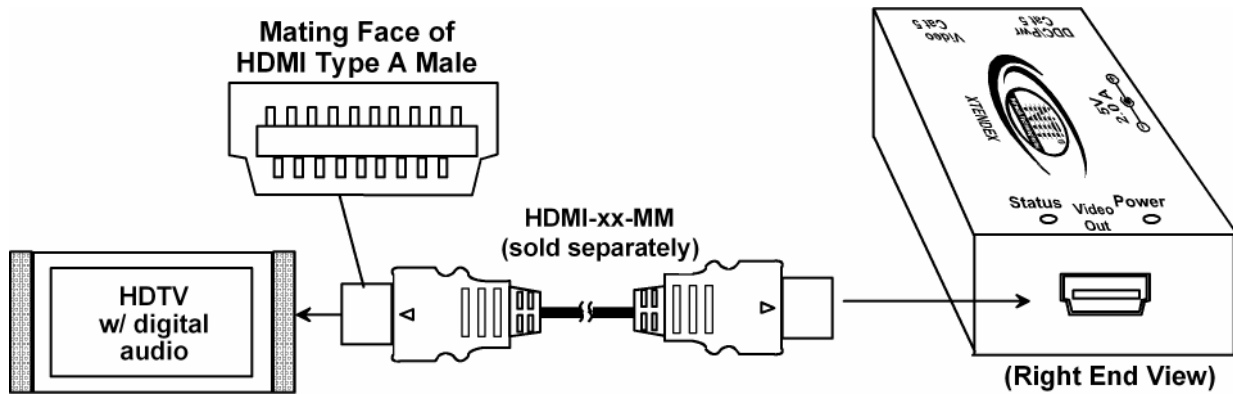

Figure 1- Connect the extended video display to the Remote Unit

Installing The Local Unit

Connect an HDMI cable between the video source and the "Video In" connector on the Local Unit.

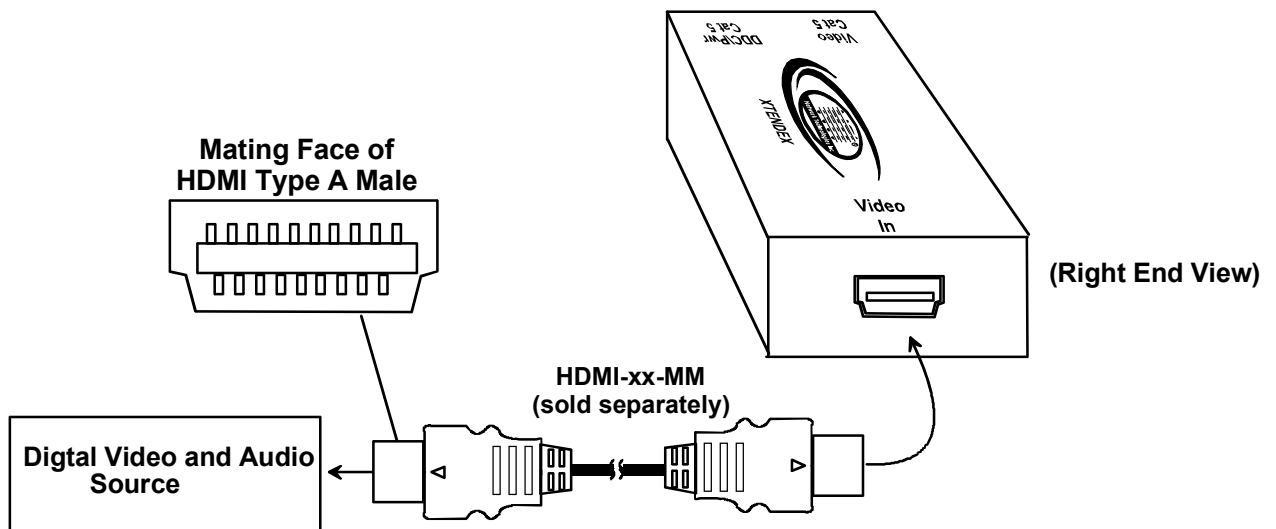

Figure 2- Connect the XTENDEX Local Unit to the source

Connect the CAT5 Cables

Connect the CAT5 cables between the "Cat5" ports on the Local and Remote Unit. (See Fig. 3.) When properly inserted the cable ends should snap into place. Be sure to connect the cable from the Remote Unit "Video Cat5" port to the "Video Cat5" port on the Local Unit and to connect the cable from the Remote Unit "DDC/PWR Cat5" port to the "DDC/PWR Cat5" port on the Local Unit. DO NOT get them mixed up or damage to the unit may occur.

Note: The two cables must be connected to like ports at each end of the cables. Powering the unit with the cables crossed may damage it.



WARNING: Never connect the XTENDEX to an Ethernet card, Ethernet router, hub or switch or other Ethernet RJ45 connector of an Ethernet device. Damage to devices connected to the Ethernet may result.

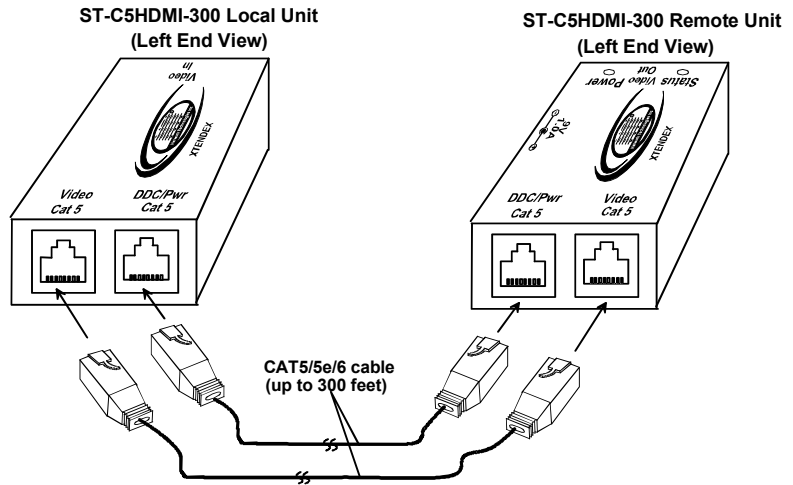

Figure 3- Connect CAT5 cables

Plug-in and Boot Up

1. Plug the power cord from the monitor into the power outlet.
2. Connect the AC adapter power connector to the 5VDC port on the Remote Unit. Plug the AC adapter into a power outlet. The red "Power" LED on the Remote Unit should illuminate, indicating that a proper power connection has been made to it. (See Figs. 4 and 5.)
3. Turn ON the Video/Audio source and Video device. The source and device should each react as if directly connected to each other.

Note: The blue "Status" LED on the Remote will illuminate when input video is available from the source. (See Fig. 5)

FYI: In many cases, the AC adapter can be omitted. The AC adapter is only needed when the signal source has insufficient strength to power the XTENDEX.

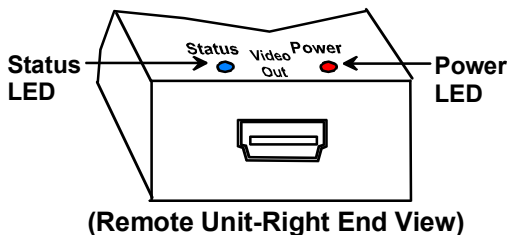

Figure 5- LEDs on Remote Unit

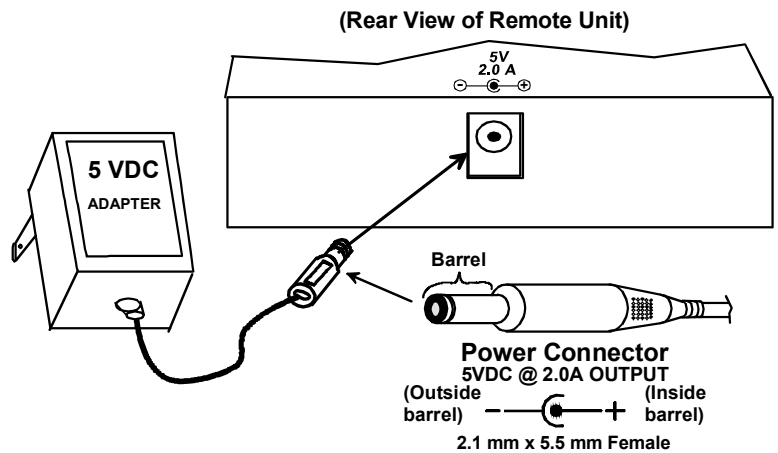

Figure 4- Connect the AC adapter to the Remote Unit

TECHNICAL SPECIFICATIONS

Video	
Video Compatibility	PC Resolution up to 1920x1200 @60Hz / HDTV resolution up to 1080i
Video Connectors	HDMA Type A Female
Input Video Signal	5 volts p-p (TTL)
Video Color Format	Deep color 24bit/36bit
HDMI Version	HDMI 1.3
HDCP Version	HDCP 1.3
Audio	
Audio Format	LPCM,Dolby-AC3,DTS7.1,DSD
General	
Interconnect Cable	CAT5/5e/6 Solid UTP EIA/TIA 568 B wiring with male RJ45 connectors
Operating Temperature	-5 to +55° C
Operating Humidity Range	5 to 90% RH (no condensation)
Remote Unit Power	110V or 220VAC at 50 or 60Hz-5VDC/2.0A via AC Adapter
Local Unit Power	powered by Remote Unit through CAT5 cable or by Video/Audio source
Enclosure type	Electro-galvanized steel black powder coated
Size (In.) WxDxH	1.8x3.3x0.9

**Distances and Resolutions for CAT5,CAT5e and CAT6 Cables
Solid Unshielded (UTP) and Shielded (STP) Twisted Pair Resolutions**

CABLE	DISTANCE (FEET)	MAXIMUM PC RESOLUTIONS	CABLE	DISTANCE (FEET)	MAXIMUM HDTV RESOLUTIONS
CAT5 (UTP)	200	1024 x 768 at 60Hz	CAT5 (UTP)	200	480p
	150	1280 x 1024 at 60Hz		150	720p
	100	1920 x 1200 at 60Hz		100	1080i
CAT5e (UTP)	250	800 x 600 at 60Hz	CAT5e (UTP)	250	480p
	200	1024 x 768 at 60Hz		200	1080i
	150	1280 x 1024 at 60Hz		150	
	100	1920 x 1200 at 60Hz		100	
CAT6 (UTP)	275	800 x 600 at 60Hz	CAT6 (UTP)	275	480p
	250	1024 x 768 at 60Hz		250	1080i
	200	1280 x 1024 at 60Hz		200	
	100	1920 x 1200 at 60Hz		100	
CAT6 (STP)	300	800 x 600 at 60Hz	CAT6 (STP)	300	480p
		1024 x 768 at 60Hz		200	1080i
	200	1280 x 1024 at 60Hz		100	
	100	1920 x 1200 at 60Hz			

INTERCONNECTION CABLE WIRING METHOD

The CAT5 connection cables between the Remote and Local are terminated with RJ45 connectors and must be wired according to the EIA/TIA 568 B industry standard. Wiring is per the table and drawing below.

Pin	Wire Color	Pair	Function
1	White/Orange	2	T
2	Orange	2	R
3	White/Green	3	T
4	Blue	1	R
5	White/Blue	1	T
6	Green	3	R
7	White/Brown	4	T
8	Brown	4	R

Figure 6- View looking into RJ45 female

TROUBLESHOOTING

Each and every piece of every product produced by Network Technologies Inc is 100% tested to exacting specifications. We make every effort to insure trouble-free installation and operation of our products. If problems are experienced while installing this product, please look over the troubleshooting chart below to see if perhaps we can answer any questions that arise. If the answer is not found in the chart, please check the FAQs (Frequently Asked Questions) on our website at <http://www.networktechinc.com> or contact us directly for help at 1-800-742-8324 (800-RGB-TECH) in US & Canada or 1-330-562-7070 worldwide. We will be happy to assist in any way we can.

Problem	Cause	Solution
Remote Unit red power LED does not illuminate	<ul style="list-style-type: none"> Power supply is not connected or plugged-in. 	<ul style="list-style-type: none"> Make sure outlet is live and AC adapter is plugged-in. Make sure 5VDC jack is fully connected
No Video on monitor	<ul style="list-style-type: none"> One or more video cables is loose or disconnected. No power to Remote Unit. CAT5 cable is not connected. CAT5 cable is too long 	<ul style="list-style-type: none"> Check all video cable connections Make sure red "Power" LED is illuminated on remote. If not, see solutions for first problem above. With all the cables properly connected, power cycle the video/audio source. Make sure blue "Status" LED on remote is illuminated. Make sure they are snapped-in properly and completely and reboot. Switch to shorter cable or lower resolution (see table on page 7)
Video Picture is noisy, lines on pixels out of position on wiring color	<ul style="list-style-type: none"> All Video Cables are not firmly seated. CAT5 cable is too long. The CAT5 cable is not properly connected. 	<ul style="list-style-type: none"> Check all connections. Make sure all cables are fully seated. Switch to shorter cable or lower resolution (see table on page 7) Check cable connections. Make sure they are snapped-in properly and completely.
Monitor sometimes loses sync, causing it to go blank for a second or two	<ul style="list-style-type: none"> Electrical power system is very noisy, particularly the ground. The CAT5 cable is not properly connected. CAT5 cable is too long 	<ul style="list-style-type: none"> Make sure the interconnection cable is not near any power lines. Check cable connections. Make sure they are snapped-in properly and completely. Switch to shorter cable or lower resolution (see table on page 6)

WARRANTY INFORMATION

The warranty period on this product (parts and labor) is two (2) years from the date of purchase. Please contact Network Technologies Inc at (800) 742-8324 (800-RGB-TECH) or (330) 562-7070 or visit our website at <http://www.networktechinc.com/return-policy.html> for information regarding repairs and/or returns. A return authorization number is required for all repairs/returns.