

E-LD-SPDT

Liquid Detector with SPDT Contacts

DESCRIPTION

The **E-LD-SPDT** water detector features gold-plated probes and microchip technology for dependable detection of conductive liquids. The E-LD-SPDT can be operated from 11-27 VAC/VDC. For application flexibility, SPDT contacts are provided to connect to a monitoring system. A height-adjustable, cast-aluminum, weatherproof enclosure is standard. A green LED visible outside the box indicates power. A red LED indicates water detected.

FEATURES

- *Weatherproof enclosure*
- *Easy to install*
- *SPDT alarm contacts*
- *11-27 VAC/DC(50/60 Hz)*
- *Reliable operation*
- *LEDs for power and alarm indication (green, red)*
- *Adjustable detection level*

OPERATION

The **E-LD-SPDT** can be used with any contact-closure monitoring panel. The SPDT contacts may be wired normally open or normally closed, allowing wiring flexibility to handle most installations.

MOUNTING

Secure by applying a silicone adhesive to the mounting feet and placing the sensor in the area to be protected. For more permanent installations, fasten the sensor using the 0.19"(0.48 cm) holes provided in the mounting feet with #6 or #8 screws. The legs are adjustable 1.5" (3.81 cm) for precise water level signaling.



DIMENSIONS

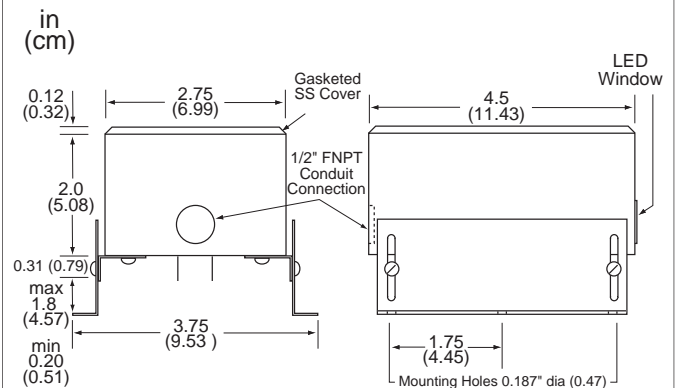

Probe height adjustable 0" to 1.5" (0 to 3.8 cm)

WIRING

The E-LD-SPDT is provided with a 1/2" FNPT conduit connection in the end of the enclosure. Terminations are made to the color-coded wires with field-supplied connectors.

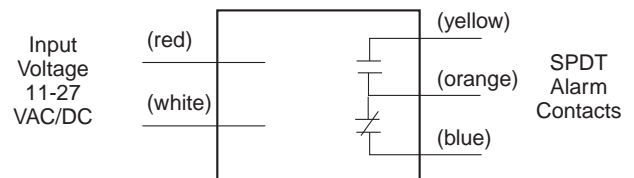

If grounded AC power is used, the grounded power supply lead must be connected to the white lead on the E-LD-SPDT, or the unit may fail to operate.

SPECIFICATIONS

Supply Voltage	11 -27 VAC/VDC
Supply Current	
VDC	10 mA typical, 30 mA maximum
VAC	30 mA typical, 70 mA maximum
Relay Outputs	SPDT contacts rated, 1A @ 24 VAC/VDC, 1/2A @ 120 VAC
Operating Temperature	32° to 158°F (0° to 70°C)
Enclosure Rating	Cast aluminum, weather resistant with adjustable legs
Dimensions	4.23"H X 3.75"W X 4.5"W (10.7 X 9.5 X 11.4 cm)
Approvals	CE
Weight	0.98 lb (6.44 kg)
Warranty	24 Months

Schematics for wiring Liquid Detector to DIGITAL IN Terminals

E-16D

VIEW OF TERMINALS ON E-16D



For up to 1000 ft applications,
19-25AWG Interconnect cable
may be used

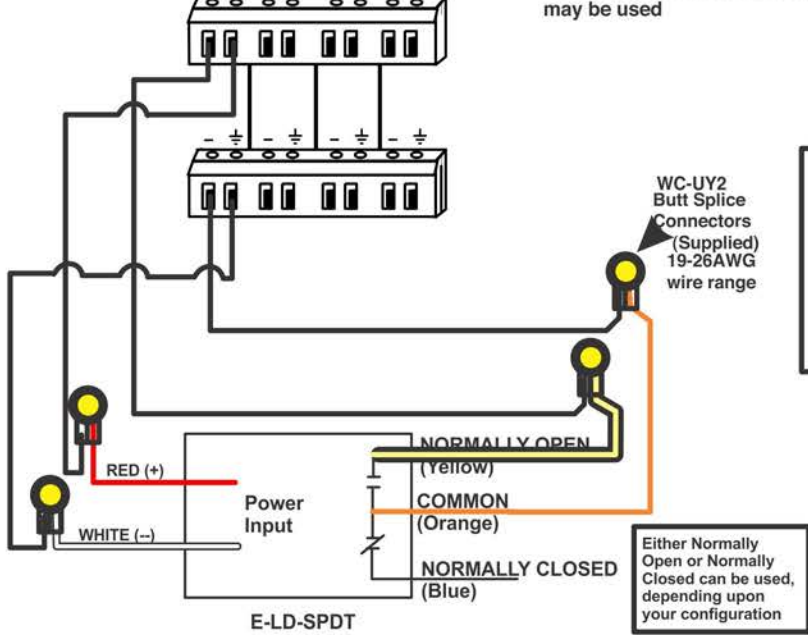

E-5D

VIEW OF TERMINALS ON E-5D

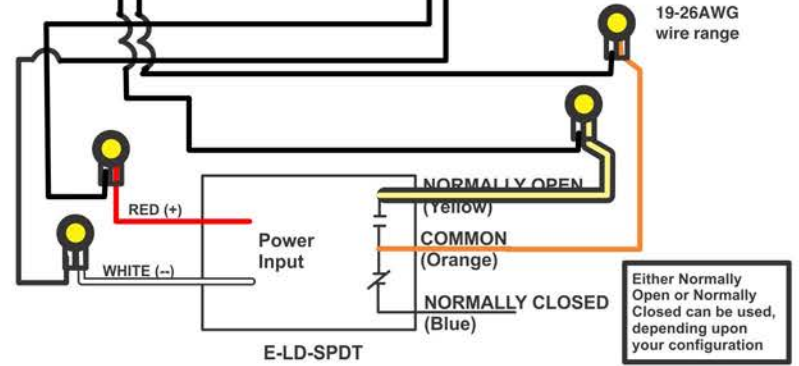
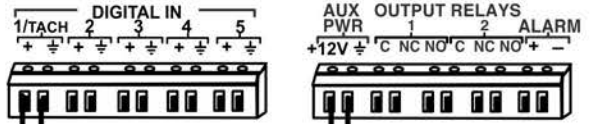

E-2D

VIEW OF TERMINALS ON E-2D

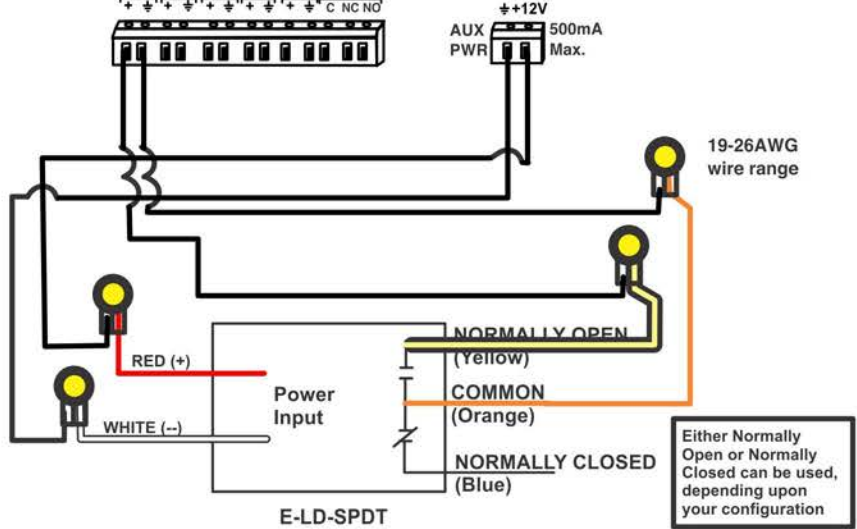
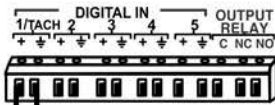

E-MINI-LXO

VIEW OF TERMINALS ON E-MINI-LXO

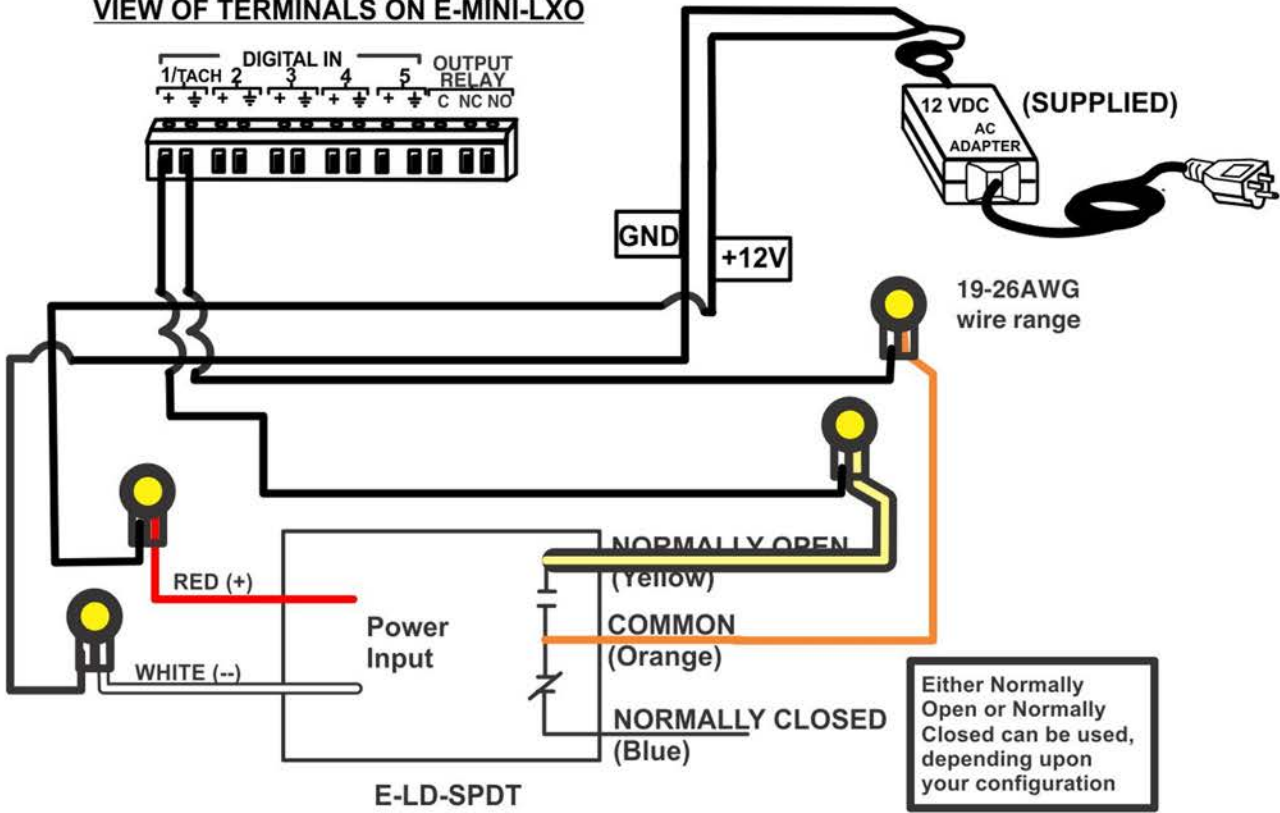

E-MICRO-T(RHP) / E-1W(P)

