

ENVIROMUX-SLDO-14

SPOT LEAK DETECTOR

DESCRIPTION

The ENVIROMUX-SLDO-14 spot leak detector is an economical solution for detecting fluids in small, confined areas, such as drip pans. The unit is designed with polymer coated sensing probes to detect conductive fluids at a single point. The height of the probes can easily be adjusted to the desired position by simply bending them. Units can be screwed or glued to the floor or baseboard for quick installation.

The ENVIROMUX-SLDO-14 will provide notification of leakage when used in conjunction with an ENVIROMUX-2D/-5D/-16D or ENVIROMUX-MINI-LXO Server Environment Monitoring System (SEMS).



FEATURES

- Adjustable sensing probe height (from 0" to 0.75")
- Small footprint
- No exposed metal sensing posts
- All components encapsulated against moisture
- Switching capability 0.5A at 120 VAC
- Simple installation



SPECIFICATIONS

Supply Voltage	24 VAC, 0.1A (supplied)	Cable Length	14' (4.27m)
Contact Rating	1A @ 24 VAC, 0.5A @ 120 VAC resistive	Dimensions	2.0"H x 1.55"W x 1.0"D (5.1 x 3.9 x 2.5 cm)
Contact Type	SPDT	Approvals	CE, RoHS
Operating Temperature	32° to 122°F (0° to 50°C)	Weight	0.4 lb (0.2 kg)
Storage Humidity	5% to 95% non-condensing	Warranty	1 year

WIRING

Connect the white (N/O) and green (Com) or blue (N/C) leads to the SEMS. Connect the black (-) and red (+) leads to the power source. Test the ENVIROMUX-SLDO-14 by placing water under the sensing probes.

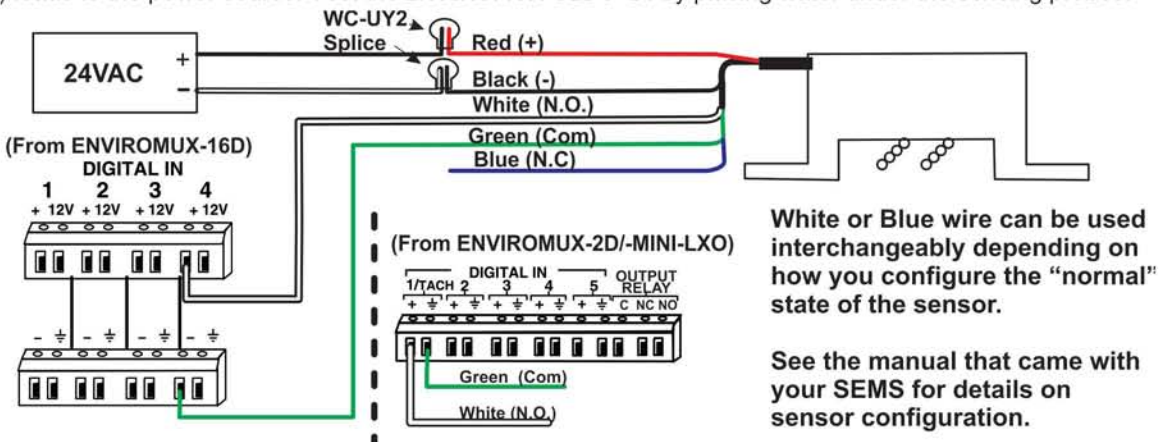

INSTALLATION NOTE

The angle of the sensing probes can be adjusted to change the sensitivity of the ENVIROMUX-SLDO-14. The closer the probes are to the floor, the smaller the quantity of water required to trigger the sensor. Adjust the sensing probes to the desired height. Make sure the probes don't touch each other.

